



Service Manual

**Lexmark X63
All-In-One
4400-001**

- ***Table of Contents***
- ***Start Diagnostics***
- ***Safety and Notices***
- ***Trademarks***
- ***Index***

LEXMARK™

Lexmark and Lexmark with diamond design are trademarks of Lexmark International, Inc., registered in the United States and/or other countries.

4400-001

Edition: September, 2001

The following paragraph does not apply to any country where such provisions are inconsistent with local law: LEXMARK INTERNATIONAL, INC. PROVIDES THIS PUBLICATION "AS IS" WITHOUT WARRANTY OF ANY KIND, EITHER EXPRESS OR IMPLIED, INCLUDING, BUT NOT LIMITED TO, THE IMPLIED WARRANTIES OF MERCHANTABILITY OR FITNESS FOR A PARTICULAR PURPOSE. Some states do not allow disclaimer of express or implied warranties in certain transactions; therefore, this statement may not apply to you.

This publication could include technical inaccuracies or typographical errors. Changes are periodically made to the information herein; these changes will be incorporated in later editions. Improvements or changes in the products or the programs described may be made at any time.

Comments may be addressed to Lexmark International, Inc., Department D22A/032-2, 740 West New Circle Road, Lexington, Kentucky 40550, U.S.A or e-mail at ServiceInfoAndTraining@Lexmark.com. Lexmark may use or distribute any of the information you supply in any way it believes appropriate without incurring any obligation to you. You can purchase additional copies of publications related to this product by calling 1-800-553-9727. In other countries, contact your point of purchase.

Lexmark and Lexmark with diamond design are trademarks of Lexmark International, Inc., registered in the United States and/or other countries.

Other trademarks are the property of their respective owners.

© Copyright Lexmark International, Inc. 2001.

All rights reserved.

UNITED STATES GOVERNMENT RESTRICTED RIGHTS

This software and documentation are provided with RESTRICTED RIGHTS. Use, duplication or disclosure by the Government is subject to restrictions as set forth in subparagraph (c)(1)(ii) of the Rights in Technical Data and Computer Software clause at DFARS 252.227-7013 and in applicable FAR provisions: Lexmark International, Inc., Lexington, KY 40550.

P/N 12G9074

Table of Contents

Safety Information	v
Preface	x
General Information	1-1
Specifications	1-2
Printer Engine	1-2
Printhead	1-2
Facsimile	1-3
Scanner	1-5
Power and Size	1-5
Abbreviations	1-5
Diagnostic Information	2-1
Start	2-1
Power-On Self Test (POST) Sequence	2-1
POST Symptom Table	2-2
Symptom Tables	2-3
Service Checks	2-7
Carrier Transport Service Check	2-7
CIS Assembly Service Check	2-9
Scanner Motor with Gear Assembly Service Check	2-10
Maintenance Station Service Check	2-11
Paper Feed Service Check	2-12
Paper Path Service Check	2-14
Power Service Check	2-15
Print Quality Service Check	2-16
Scan/Copy Quality Service Check	2-18
Fax/Telephone Communication Service Check	2-19
Diagnostic Aids	3-1
Theory of Mechanism	3-1
Scanner Mechanism	3-1
Drive Feed Roller Assembly	3-1
Contact Image Sensor (CIS)	3-2
Document Sensors	3-2
Repair Information	4-1
Handling ESD-Sensitive Parts	4-1
Adjustments	4-2
Removal Procedures	4-2

- Releasing Plastic Latches4-2
- Removals4-3
 - General Precautions on Removals.....4-3
 - CIS White Roller Assembly Removal.....4-4
 - Top Cover Assembly Removal.....4-5
 - Rollers (Drive Feed Roller Assembly, Exit Shaft) Removal . . .4-6
 - CIS (Contact Image Sensor) Removal.....4-7
 - Scanner Motor with Gear Assembly Removal4-9
 - Power Supply Removal4-11
 - Line Interface Board Removal4-13
 - Operator Panel Assembly Removal.....4-15
 - Printer Unit Removal4-16
 - ASF Assembly Removal.....4-17
 - Maintenance Station Removal.....4-19
 - Carrier Assembly with Belt Removal4-20
 - System Board Removal4-21
 - Mid Frame Assembly with Exit Rollers Removal4-22
 - Large Feed Roller Assembly with Gear Removal4-23
 - Paper Feed Motor Assembly with Gears Removal4-24
 - Carrier Transport Motor Removal.....4-25
- Connector Locations**5-1
 - System Board.....5-1
 - Logic Card5-2
 - Power Supply.....5-3
- Preventive Maintenance**6-1
 - Lubrication Specifications6-1
- Parts Catalog**7-1
 - How to Use This Parts Catalog7-1
- Index**I-1

Safety Information

- This product is designed, tested and approved to meet strict global safety standards with the use of specific Lexmark components. The safety features of some parts may not always be obvious. Lexmark is not responsible for the use of other replacement parts.
- The maintenance information for this product has been prepared for use by a professional service person and is not intended to be used by others.
- There may be an increased risk of electric shock and personal injury during disassembly and servicing of this product. Professional service personnel should understand this and take necessary precautions.

Consignes de Sécurité

- Ce produit a été conçu, testé et approuvé pour respecter les normes strictes de sécurité globale lors de l'utilisation de composants Lexmark spécifiques. Les caractéristiques de sécurité de certains éléments ne sont pas toujours évidentes. Lexmark ne peut être tenu responsable de l'utilisation d'autres pièces de rechange.
- Les consignes d'entretien et de réparation de ce produit s'adressent uniquement à un personnel de maintenance qualifié.
- Le démontage et l'entretien de ce produit pouvant présenter certains risques électriques, le personnel d'entretien qualifié devra prendre toutes les précautions nécessaires.

Norme di sicurezza

- Il prodotto è stato progettato, testato e approvato in conformità a severi standard di sicurezza e per l'utilizzo con componenti Lexmark specifici. Le caratteristiche di sicurezza di alcune parti non sempre sono di immediata comprensione. Lexmark non è responsabile per l'utilizzo di parti di ricambio di altri produttori.
- Le informazioni riguardanti la manutenzione di questo prodotto sono indirizzate soltanto al personale di assistenza autorizzato.
- Durante lo smontaggio e la manutenzione di questo prodotto, il rischio di subire scosse elettriche e danni alla persona è più elevato. Il personale di assistenza autorizzato, deve, quindi, adottare le precauzioni necessarie.

Sicherheitshinweise

- Dieses Produkt und die zugehörigen Komponenten wurden entworfen und getestet, um beim Einsatz die weltweit gültigen Sicherheitsanforderungen zu erfüllen. Die sicherheitsrelevanten Funktionen der Bauteile und Optionen sind nicht immer offensichtlich. Sofern Teile eingesetzt werden, die nicht von Lexmark sind, wird von Lexmark keinerlei Verantwortung oder Haftung für dieses Produkt übernommen.
- Die Wartungsinformationen für dieses Produkt sind ausschließlich für die Verwendung durch einen Wartungsfachmann bestimmt.
- Während des Auseinandernehmens und der Wartung des Geräts besteht ein zusätzliches Risiko eines elektrischen Schlags und körperlicher Verletzung. Das zuständige Fachpersonal sollte entsprechende Vorsichtsmaßnahmen treffen.

Pautas de Seguridad

- Este producto se ha diseñado, verificado y aprobado para cumplir los más estrictos estándares de seguridad global usando los componentes específicos de Lexmark. Puede que las características de seguridad de algunas piezas no sean siempre evidentes. Lexmark no se hace responsable del uso de otras piezas de recambio.
- La información sobre el mantenimiento de este producto está dirigida exclusivamente al personal cualificado de mantenimiento.
- Existe mayor riesgo de descarga eléctrica y de daños personales durante el desmontaje y la reparación de la máquina. El personal cualificado debe ser consciente de este peligro y tomar las precauciones necesarias.

Informações de Segurança

- Este produto foi concebido, testado e aprovado para satisfazer os padrões globais de segurança na utilização de componentes específicos da Lexmark. As funções de segurança de alguns dos componentes podem não ser sempre óbvias. A Lexmark não é responsável pela utilização de outros componentes de substituição.
- As informações de segurança relativas a este produto destinam-se a profissionais destes serviços e não devem ser utilizadas por outras pessoas.
- Risco de choques eléctricos e ferimentos graves durante a desmontagem e manutenção deste produto. Os profissionais destes serviços devem estar avisados deste facto e tomar os cuidados necessários.

Informació de Seguretat

- Aquest producte està dissenyat, comprovat i aprovat per tal d'acomplir les estrictes normes de seguretat globals amb la utililització de components específics de Lexmark. Les característiques de seguretat d'algunes peces pot ser que no sempre siguin òbvies. Lexmark no es responsabilitza de l'ús d'altres peces de recanvi.
- La informació pel manteniment d'aquest producte està orientada exclusivament a professionals i no està destinada a ningú que no ho sigui.
- El risc de xoc elèctric i de danys personals pot augmentar durant el procés de desmuntatge i de servei d'aquest producte. El personal professional ha d'estar-ne assabentat i prendre les mesures convenients.

안전 사항

- 본 제품에 관한 유지 보수 설명서는 전문 서비스 기술자 용으로 작성된 것이므로 비 전문가가 사용할 수 없습니다.
- 본제품을 해체하거나 정비할 경우 전기적인 충격을 받거나 상처를 입을 위험이 커집니다. 전문 서비스 기술자는 이 사실을 숙지하고 필요한 예방 조치를 취하도록 하십시오.
- 일부 부품의 안전성은 항상 보장되지 않습니다. 따라서, 교체 부품은 원래 부품과 같거나 동등한 특성을 가진 제품을 사용하여야합니다.

安全资讯

- 本产品的维护资讯仅供专业服务人员使用，而非针对一般使用者。
- 本产品在拆卸、维修的时候，遭受电击或人员受伤的危险性会增高，专业服务人员对这点必须有所了解，并采取必要的预防措施。
- 有些零件的安全功能可能不明显。因此，所替换零件的性能一定要与原有的零件一致。

Preface

This manual contains maintenance procedures for service personnel. It is divided into the following chapters:

1. **General Information** contains a general description of the printer and the maintenance approach used to repair it. Special tools and test equipment are listed.
2. **Diagnostic Information** contains an error indicator table, symptom tables, and service checks used to isolate failing field replaceable units (FRUs).
3. **Diagnostic Aids** contains tests and checks used to locate or repeat symptoms of printer problems.
4. **Repair Information** provides instructions for making printer adjustments and removing and installing FRUs.
5. **Connector Locations** uses illustrations to identify the connector locations and test points on the printer.
6. **Preventive Maintenance** contains the lubrication specifications and recommendations to prevent problems.
7. **Parts Catalog** contains illustrations and part numbers for individual FRUs.

1. General Information

The Lexmark™ X63 All-In-One is a letter quality print, fax, copy and scan machine. The printhead uses small heater plates and nozzles to control ink flow and the formation of characters on the print media. The printhead assembly and ink supply are combined into a single unit. Print cartridges are available as a customer replaceable supply item. Dual printheads provide color and true black printing without changing printheads. The number and size of inkjets or nozzles, in the printhead, determines the overall quality and capability of the printer. The black cartridge has a total of 208 nozzles and installs on the right. The color cartridge has a total of 192 nozzles and installs on the left. The printer is capable of printing in both directions from either cartridge.

Specifications

Printer Engine

Technology		Thermal Inkjet
		2-pin and printhead swapping type
Speed	Color	6 ppm at Draft Mode
	Mono	12 ppm at Draft Mode
Resolution	Color	600 X 600 dpi (1200 X 2400 dpi Addressable)
	Mono	600 X 600 dpi (1200 X 2400 dpi Addressable)
Printing Width		203 mm
Feeding Method	Automatic	100 sheets of 20 lb cut sheets (Max 10 mm)
	Manual Tray	No
Emulation		Host Based Printing (GDI)
Printer Driver		Windows 98/2000 Driver
Interface		USB Interface

Printhead

	Babbage Mono Standard	Birch Color
Printhead	208 nozzles	192 nozzles
Ink Type	Pigment	Dye
Ink Color	Black	Color
Ink Yield	About 600 sheets	About 200 sheets

Facsimile

General	Compatibility	ITU-G3
	Scan Method	CIS
	Scan Width	Maximum 216 mm, Effective 210 mm
	Scan Resolution	300 X 300 dpi
	Scan Speed	7 seconds
	Feeding Method	Sheet-Feed
	ADF	20 sheets of 20 pound
	Guide	Document Input Guide
	Stacker	Document Output Stacker/Paper Stacker
	Paper Tray	Bin Type (without Manual Tray)
	Modem Speed	14.4 Kbps
	Coding Method	MH, MR, MMR, Error Correction Mode
	LCD	2 lines of 16 characters each
Scanning	Resolution and Type	Standard: 203 X 98 dpi Fine: 203 X 196 dpi (default) Superfine: 300 X 300 dpi
	Contrast	Darkest/Darken/Normal Lighten/Lightest
Memory	Capacity	1 Mbyte
	Back-up Time	15 sec (Continuous power failure, typically 1-2 minutes)
	Confidential	No
	Forced Memory TX	Yes
	Memory RX	Automatic reception when paper empty.

4400-001

Telephone	Speed Dial	70 locations
	Chain Dial	No
	On-Hook Dial	Yes, 1-Key
	Last Number Redial	Yes, 1-Key
	Auto Redial	Yes
	Hold and Mute	No
	Pause	Yes, use Redial Key
	Ringer Volume	S/W Option Setting (4 steps)
	Tone/Pulse Select	Only Tone Mode
	DRPD	USA: Yes, Other Countries: No
Report and List	TX/RX Journal	Yes
	Image TCR	Yes, Reduction of first page sent by Memory TX
	System Data	Yes
	Telephone Number List	Yes
	Self Test	Yes
Copy	Multipage Copy	Up to 99 pages
	Grayscale	256 levels
	Reduction and Enlargement	25% - 200% (Reference is the top center of document.)
Telephone I/F	Answering I/F	Yes
	Extension Phone	1-jack, extension phone transfer
Others	Sensors	Paper Jam
	Real Time Clock	No
	RTI	Yes

4400-001

Scanner

Compatibility	TWAIN
Technology	Platen CIS
Light Source for Color CIS	RGB LEDs (Line Order Control)

Power and Size

Power Source	110V-240V / 50Hz-60Hz
Dimensions	440.6 X 319.6 X 205.4 mm
Weight (Packed Weight)	5.6 Kg (8.0 Kg packed weight)

Abbreviations

ASF	Auto Sheet Feed
B/M	Bill of Material
CIS	Contact Image Sensor
EOF	End of Form
ESD	Electrostatic Discharge
FPC	Flat Printhead Cable
FRU	Field Replaceable Unit
HVPS	High Voltage Power Supply
LCD	Liquid Crystal Display
LVPS	Low Voltage Power Supply
OEM	Original Equipment Manufacturer
V ac	Volts alternating current
V dc	Volts direct current
ZIF	Zero Insertion Force

4400-001

2. Diagnostic Information

Start

Power-On Self Test (POST) Sequence

1. CIS light turns on then turns off.
2. Carrier moves to the left and the paper feed motor runs then stops.
3. Carrier returns to the right.
4. "Powering Up Please Wait" is displayed on the LCD.
5. Ready, ANS/FAX, the Date and Time display when POST is complete.

If your printer completes POST with no errors, go to the **"Symptom Tables" on page 2-3**. Locate the symptom and take the indicated action.

If your printer does not complete POST, locate the symptom in the following table and take the indicated action.

POST Symptom Table

Symptom	Action
LCD or operator panel buttons do not work and no motors run	Go to the “Power Service Check” on page 2-15 . If okay, go to the “Operator Panel Problems” on page 2-3 .
Paper feed gears do not turn	Go to the “Paper Feed Service Check” on page 2-12 .
Carrier does not move	Go to the “Carrier Transport Service Check” on page 2-7 .
Carrier slams side frame	Go to the “Carrier Transport Service Check” on page 2-7 .
CIS light does not turn on	Go to the “CIS Assembly Service Check” on page 2-9 .

Symptom Tables

Locate the symptom in the following tables and take the appropriate action.

Carrier Transport Problems

Symptom	Action
<ul style="list-style-type: none"> • No carrier movement • Slow carrier movement • Carrier stops • Carrier slams side frame 	Go to the “Carrier Transport Service Check” on page 2-7.

Maintenance Station Problems

Symptom	Action
Maintenance station: <ul style="list-style-type: none"> • Fails to cap the printheads • Fails to clean the printheads 	Go to the “Maintenance Station Service Check” on page 2-11.

Operator Panel Problems

Symptom	Action
<ul style="list-style-type: none"> • Buttons do not work • LCD does not display 	<p>Check operator panel cable connection at CN17 on the system board. Then run the “Power-On Self Test (POST) Sequence” on page 2-1. If the LCD or buttons fail, check connection CN17. If the problem remains, replace the operator panel assembly. Go to the “Operator Panel Assembly Removal” on page 4-15.</p> <p>If the problem still exists, replace the system board. Go to the “System Board Removal” on page 4-21.</p>

Symptom	Action
Document scan sensor does not detect document	Check operator panel cable connector CN17 on the system board. If okay, go to the “Scanner Motor with Gear Assembly Service Check” on page 2-10 . If the scanner motor is working correctly, replace the operator panel assembly. Go to the “Operator Panel Assembly Removal” on page 4-15 .

Printer Communication Table

Symptom	Action
Not able to print Self Test Page	Check the USB cable and system board cable connections. If okay, replace system board. Go to the “System Board Removal” on page 4-21.

Scanner Problems

Symptom	Action
Light does not turn on	Go to the “CIS Assembly Service Check” on page 2-9.
<ul style="list-style-type: none"> Scanned images are faded, or colors are dull, blurry or fuzzy. Images are slanted or crooked and the straight lines in the image appear to be jagged or uneven. Blank copies 	Go to the “Scan/Copy Quality Service Check” on page 2-18.
<ul style="list-style-type: none"> Scanner motor does not run Document sensor does not work 	<p>Go to the “Scanner Motor with Gear Assembly Service Check” on page 2-10.</p> <p>Go to the “Operator Panel Problems” on page 2-3.</p>
<ul style="list-style-type: none"> CIS white roller assembly slips Paper will not feed correctly 	Go to the “Paper Path Service Check” on page 2-14.

Paper Feed Problems

Symptom	Action
<ul style="list-style-type: none"> • Fails to pick paper • Picks more than one sheet of paper • Picks paper but fails to feed • Paper jams • Paper fails to exit • Noisy paper feed 	Go to the “Paper Feed Service Check” on page 2-12.
Envelopes fail to feed	Go to the “Paper Feed Service Check” on page 2-12.
Paper skews	Go to the “Paper Path Service Check” on page 2-14.

Power Problems

Symptom	Action
No power in machine, motors do not operate	Go to the “Power Service Check” on page 2-15.

Print Quality Problems

Symptom	Action
<ul style="list-style-type: none"> • Voids in characters • Light print • Prints off the page • Fuzzy print • Carrier moves but no print • Printhead dries prematurely • Colors print incorrectly • Vertical alignment off 	Go to the “Print Quality Service Check” on page 2-16.
<ul style="list-style-type: none"> • Ink smearing • Vertical streaks on paper • Print lines crowded 	Go to the “Paper Feed Service Check” on page 2-12.

Service Checks

Carrier Transport Service Check

	FRU	Action
1	System Board Carrier Transport Motor	Check the carrier transport motor connector CN5. If connected, check for approximately 28 volts on pins 1 and 2 or at the wire connections located on the rear of the carrier transport motor. If voltage is incorrect, replace the system board. If voltage is correct, check the motor for shorts.
2	Carrier Transport Motor	<p>Check the motor for binds, or loose motor pulley.</p> <p>A noisy or chattering motor or a motor that fails to turn can be caused by:</p> <ul style="list-style-type: none"> • An open or short in the motor • An open or short in the motor driver on the system board • A bind in the carrier transport mechanism <p>With the carrier transport motor cable (CN5) disconnected from the system board, check for 0 to 16 ohms between the following pins on the motor:</p> <p>CN5-1 and CN5-2</p> <p>If the readings are incorrect, replace the print engine. Go to the “Carrier Transport Motor Removal” on page 4-25.</p>
3	Carrier Guide Rod	<p>Clean the carrier rod.</p> <p>Note: Lubricate the rod and the carrier rod bearing surfaces with grease P/N 99A0394.</p>

	FRU	Action
4	Encoder Strip Carrier Assembly with Belt	<p>Check the encoder strip for proper installation. Also, check it for wear, dirt and grease. Replace if needed.</p> <p>Be sure all printhead connectors are fully seated. Check the cables for damage.</p> <p>If the encoder strip and all connections are okay, but the carrier still slams the side frame, replace the carrier assembly with belt. Go to the “Carrier Assembly with Belt Removal” on page 4-20. If problem remains, replace the system board. Go to the “System Board Removal” on page 4-21</p>
5	Carrier Transport Belt Idler Pulley Assembly	<p>Check for worn, loose or broken parts. Check for obstructions blocking carrier movement. If pulley assembly is damaged, replace.</p> <p>Lubricate carrier to carrier frame engagement with grease P/N 99A0394.</p>
6	Maintenance Station	<p>A problem with the maintenance station can cause carrier movement problems at the right margin. Go to the “Maintenance Station Removal” on page 4-19.</p>
7	Access Door Sensor	<p>If the carrier does not move toward the cartridge load position when the access door is opened, verify that power is on. If the carrier still does not move, check connector CN12 pin 1 for approximately 4 volts, with the door open. If the voltage is correct, replace the sensor. Disconnect CN12 from the system board before removing sensor. If the voltage is incorrect, replace the system board. Go to the “System Board Removal” on page 4-21.</p>

CIS Assembly Service Check

The CIS lamp does not light when scanning is in process or during the (POST) sequence.

	FRU	Action
1	CIS Assembly	If light does not come on during the scanning process, check connector CN13 on the system board. If the connection is okay, check for a voltage reading of approximately 4 volts from ground to CN13-2 pin. If voltage is correct, replace the CIS assembly. Go to the “CIS (Contact Image Sensor) Removal” on page 4-7 . If voltage is incorrect, replace the system board. Go to the “System Board Removal” on page 4-21 .

Scanner Motor with Gear Assembly Service Check

Motor will not run.

	FRU	Action
1	Scanner Motor with Gear Assembly	<p>Check scanner motor for shorts. Disconnect connector CN8 from the system board and check for approximately 12.5 ohms between the following pins on the motor connector.</p> <p style="padding-left: 40px;">CN8-1 and CN8-2</p> <p>If the ohms reading is incorrect, replace the scanner motor assembly. If the motor does not come on during the scanning process, check connector CN8 on the system board. If the connection is okay, check for voltage reading of approximately 28 volts at pins</p> <p style="padding-left: 40px;">CN8-1 CN8-2 CN8-3 CN8-4</p> <p>If voltage is correct, replace the scanner motor with gear assembly. Go to the “Scanner Motor with Gear Assembly Removal” on page 4-9. If voltage is incorrect, replace the system board. Go to the “System Board Removal” on page 4-21.</p>
2	Document Scanner Sensor	<p>To check the document scanner sensor, insert a sheet of paper or depress the sensor to see if the scanner motor is working. Go to “Operator Panel Problems” on page 2-3.</p>

Maintenance Station Service Check

The maintenance station has three functions:

1. Wipes the printhead nozzles to clean them of dirt.
2. Provides a place for printheads to fire all nozzles, keeping them clear prior to printing.
3. Seals the printhead when it is not being used to prevent the nozzles from drying.

	FRU	Action
1	Maintenance Station Assembly	<p>As the carrier moves to the right over the maintenance station, a slot on the bottom of the carrier engages a tab on the sled of the maintenance station causing the cap to rise and seal the printhead. Carrier movement to the left uncaps the printhead. The wiper cleans the printhead nozzles as the carrier leaves the maintenance station. The wiper cleans the printhead only when the carrier is moving to the left. There should be no wiping action of the printhead nozzles when the carrier is moving to the right. After the cleaning operation is complete, a tab on the maintenance station engages a tab on the carrier, causing the wiper to lower.</p> <p>Check the maintenance station for worn or broken parts. Replace if needed. Go to the “Maintenance Station Removal” on page 4-19.</p> <p>Worn wipers cause degraded print quality just after a maintenance cleaning. Check for loose or worn wipers.</p> <p>Worn caps cause the printhead nozzles to dry and clog. Check for loose or worn caps.</p>

Paper Feed Service Check

If your machine does not have paper jam problems, continue with the service check. If your machine does have a paper jam problem, examine it for the following before you begin the service check:

- Check the entire paper path for obstructions.
- Be sure there is not too much paper in the sheet feeder.
- Be sure the correct type of paper is being used.
- Check for static in the paper.

	FRU	Action
1	System Board	Run the “Power-On Self Test (POST) Sequence” on page 2-1 . Replace parts as needed. To check the paper feed motor, disconnect the paper feed connector CN11 and check for approximately 3 ohms between pins 1 and 4. If the reading is incorrect, replace the paper feed motor assembly with gears. Go to the “Paper Feed Motor Assembly with Gears Removal” on page 4-24 . If the reading is correct, replace the system board. Go to the “System Board Removal” on page 4-21 .

	FRU	Action
2	Paper Feed Motor	<p>A noisy or chattering motor or a motor that fails to turn, can be caused by:</p> <ul style="list-style-type: none"> • An open or short in the motor • An open or short in the motor driver on the system board • A bind in the paper feed mechanism <p>With the paper feed motor cable CN11 disconnected from the system board, check for approximately 3 ohms between the following pins on the motor:</p> <p>Pin 1 to Pin 4</p> <p>If the readings are incorrect, replace the paper feed motor assembly with gears. Go to the “Paper Feed Motor Assembly with Gears Removal” on page 4-24.</p> <p>Although the paper feeds in a forward direction only, the paper feed motor turns in two directions. If the paper feed motor turns in one direction only, replace the system board. Go to the “System Board Removal” on page 4-21.</p> <p>Binds in the paper feed motor or gear train can cause intermittent false paper jam errors. Remove the paper feed motor and check the shaft for binds. Also check for a loose or worn motor gear.</p>
3	Auto Sheet Feeder Assembly	Check the pick roller for wear.
4	Mid Frame Assembly	<p>Check the following for wear:</p> <ul style="list-style-type: none"> • Small Feed rollers • Large Feed roller • Exit roller • Star rollers <p>If the mid frame assembly needs to be replaced, go to the “Mid Frame Assembly with Exit Rollers Removal” on page 4-22.</p>
5	End-of-Forms Flag and Spring	Check for binds or damage.

Paper Path Service Check

Examine the machine for the following before you begin this service check:

- Check the entire paper path for obstructions.
- Be sure the correct type of paper is being used.
- Be sure the printer is installed on a flat surface.

	FRU	Action
1	Large and Small Feed Rollers	Check for wear and binds.
2	Small Feed Roller Springs	Check for damage or disconnected springs.
3	Auto Sheet Feeder Assembly	Check the pick roller for wear.
4	Mid Frame Asm	Check the following for wear: <ul style="list-style-type: none"> • Exit roller • Star rollers
5	End-of-Forms Flag	Check for binds or damage.
6	White Roller Assembly	Check for correct installation. Check gear and bushings for damage. If damaged, replace. Go to the “CIS White Roller Assembly Removal” on page 4-4.

Power Service Check

	FRU	Action
1	Power Supply	Plug the machine into an outlet. Check for approximately 30 V dc at J5 pin 1. If voltage is incorrect, replace the power supply.
2	Printhead Cables Paper Feed Motor Carrier Transport Motor Operator Panel	Unplug the printer. Disconnect the printhead cables and plug in the printer. Look for a symptom change. Check the failing part for shorts and replace as necessary. Repeat this procedure for the carrier transport motor, paper feed motor, and operator panel.
3	System Board	If the symptom has not changed, replace the system board. Go to the “System Board Removal” on page 4-21.

Print Quality Service Check

	FRU / Function	Action
1	Printhead Cartridge	Be sure the machine contains good print cartridges.
2	Color Printhead Cartridge Cross Contamination	<p>Cross contamination of color inks results in incorrect colors printed, as when green prints for yellow, (when yellow and blue are mixed in the printhead cartridge). This problem resolves quickly as the printhead cartridge is used.</p> <p>If cross contamination occurs, check the following:</p> <ul style="list-style-type: none"> • The maintenance station wiper for damage. • The printhead nozzle plate was resealed with tape.
3	Carrier Assembly	<p>Reseat the printhead cables in the system board and check the following parts for wear or damage:</p> <ul style="list-style-type: none"> • Printhead Cartridge Latch • Latch Spring • Carrier
4	System Board Carrier Assembly	<p>Print the self test page. To enter the self test page, press the Setup button and then Menu button until "Print Report" is displayed. Press Options button until "Self Test" is displayed. Then press the Start button to print the self test page. Look for a break in the diagonal line of the nozzle test pattern. A broken line indicates one or more print nozzles are not working. Run the test again to verify the failure.</p> <p>Check the gold-plated contacts on the end of the printhead carrier cable for dirt, wear and damage. Use only a clean dry cloth to clean the contacts. If a problem is found with contacts on the carrier, replace the carrier. Go to the "Carrier Assembly with Belt Removal" on page 4-20.</p> <p>If the symptom remains, replace the system board. Go to the "System Board Removal" on page 4-21.</p>
5	Maintenance Station	<p>Intermittent nozzle failures can be caused by worn parts in the maintenance station. Go to the "Maintenance Station Removal" on page 4-19, and then return to this check.</p>

	FRU / Function	Action
6	Paper Feed	<p>Ink smudging and smearing can be caused by paper problems or problems in the paper feed area.</p> <p>Check the following:</p> <ul style="list-style-type: none"> • Correct type of paper is being used. Also check the paper for curl or wrinkles. • Feed rollers for wear, dirt, or looseness. • Gears for wear or binds. • Paper path for obstructions.
7	Carrier Transport	<p>Blurred print and voids can be caused by problems in the carrier transport area. Check the following:</p> <ul style="list-style-type: none"> • Carrier transport belt for wear. • Carrier guide rod for wear or dirt. If dirty, clean and lubricate. • Carrier to carrier frame engagement should be lubricated with grease P/N 99A0394. • Idler pulley parts for wear, damage, or looseness.
8	Alignment	<p>Uneven vertical lines can be adjusted by performing the printhead alignment adjustments in the maintenance mode. The user is directed, through the “Setting up System in User Mode” on page 3-3, to perform the printhead alignment adjustments, when replacing a printhead cartridge.</p>

Scan/Copy Quality Service Check

	FRU / Function	Action
1	Scanned images are: faded, or colors are dull, blurry or fuzzy. Images are slanted or crooked and the straight lines in the image appear to be jagged or uneven.	<p>Check the lighter/darker settings to see if it is correct.</p> <ul style="list-style-type: none"> • From the operator panel • From the Scan & Copy Control Program <p>Check to see if there is any dust or debris on the glass lens of the CIS. This may cause a poor image.</p>
2	Blank copies	<p>If blank copies found, make sure that the original document is facing down.</p> <p>Check the print cartridges to see if they need to be cleaned or replaced.</p>
3	Scanning error	<p>Ensure the USB cable is correctly installed.</p> <p>Ensure the USB cable is proper for USB specification, version 1.1.</p> <p>Start the system after twain driver is reinstalled.</p> <p>If error still occurs, replace the system board. Go to the “System Board Removal” on page 4-21.</p>

Fax/Telephone Communication Service Check

	FRU / Function	Action
1	<p>Line Interface Board or System Board.</p> <p>Cannot make telephone connection to other fax.</p>	<p>No dial tone</p> <p>Verify correct dialing method (tone or pulse). Are TEL and LINE connections reversed? Verify phone number and availability of other fax machine.</p> <p>Before dialing, press the Speaker button so you can hear the dialing process. You should hear the ring and a 0.5 second 1000 Hz calling tone from your machine, a 1 second pause, then the 3 second 2100 Hz fax response tone and a 1650 Hz - 1850 Hz "warbling" handshaking tone from the called machine.</p> <p>Check the connectors on the line interface board P1 and P2. If okay, check connector CN15 located on the system board. If problem still exists, replace the line interface board. Go to the "Line Interface Board Removal" on page 4-13. If this does not correct the problem, replace the system board. Go to the "System Board Removal" on page 4-21.</p>
2	<p>Cannot receive faxes</p>	<p>Are TEL and LINE connections reversed? Is a telephone on the same line off the hook? Is the machine connected to the wrong telephone line?</p> <p>Check for a damaged line cord to the machine. Check telephone and line cord connections.</p>

4400-001

3. Diagnostic Aids

Theory of Mechanism

Scanner Mechanism

The scanner mechanism consists of components which feed, scan, and eject the documents that are to be copied or transmitted to a remote facsimile unit. These components and their functions are explained below.

Drive Feed Roller Assembly

The drive feed roller assembly, consisting of various rollers, rubber pad, and springs, automatically separates and feeds the pages of a document over the scanning area and stacks them on the document exit tray.

Documents up to 15 pages can be placed in the drive feed roller assembly for scanning. The leading edge of the document moves the document detect sensor lever when the operator slides the stack into the drive feed roller assembly. The scan motor starts to rotate when the document detect sensor has detected the leading edge of the document. The roller feeds the first page of the document into the feeder.

The scan motor is stopped when the leading edge of the page actuates the document scan sensor. The page is now in the scan position.

The drive feed roller assembly rubber pad prevents multiple sheets from being fed. A spring provides force that the pad places on the document pages for proper separation.

The scan motor is turned on when the machine is ready to scan the document and drives the feed roller at a speed determined by the resolution selected. The scan motor is stopped after a set period of time when the trailing edge of the page releases the document scan sensor. If another page is detected as the trailing edge of the page releases the document scan sensor, the next page feeds to the scan position. The exit roller pushes the page out onto the document exit tray where it is stacked.

Contact Image Sensor (CIS)

The contact image sensor unit consist of LEDs, rod lens array, and a photo sensor. The LEDs illuminate the document to be scanned when the leading edge is detected by the document scan sensor. The LEDs turn off when the document exits the scanner mechanism.

The LEDs illuminate the document to obtain an image from the document through the rod lens array, where the image is translated into voltage levels.

Document Sensors

There are two document sensors in the scanner mechanism; the document detect and the document scan sensor. The document detect sensor, detects whether or not a document is loaded, and the document scan sensor detects the scan position of the document. The scanner mechanism consists of components which feed, scan, and eject the documents that are to be copied or transmitted to a remote facsimile unit.

Service Mode

In service mode (tech) mode, the technician checks the machine and performs various tests to isolate the cause of a malfunction.

To enter the service mode, press Menu, #, 1, 9, 3, 4 in sequence, and the LCD briefly displays T. The machine has entered service (tech) mode. While in service mode, the machine still performs all normal operations. To return to normal user mode, press Menu, #, 1, 9, 3, 4 in sequence again, or turn the power off and then on by unplugging and plugging the power cord.

Options changed while in service mode do not remain changed unless you clear the machine's memory.

4400-001**Setting up System in User Mode**

Setup	Item	Default Status
Date Jan/01/01 Time 12:00:00P	Month - Day - Year Hour - Minute - AM/PM	Jan/01/01 12:00 PM
Print Report	Fax Confirm Transmit Log Receive Log Speed Dial List Self Test	
Maintenance	Cartridge Clean Cartridge Align Scanner Init	
Paper Size	Letter/A4/Legal	Letter
Ringer Volume	Off/Low/Medium/High	Medium
Fax Print	Letter Quality/ Draft Quality	Letter Quality
Fax Forwarding	Off/Forward/Print/ Forward	Off
Fax Receive Mode	Fax/Tel/Ans/Fax/DRPD	Fax
Setup DRPD	Learn	
Auto Journal	Yes / No	
Dial Mode	Pulse / Tone	
Default Setting	Fax Type Copy Size Copy Collate Copy Contrast Copy Type Copy Paper Type	

Setting up System in Service Mode

Setup	Item	Default Status
CIS Test	Red, Green and Blue maximum and minimum peak levels	
Aging Test	Scanner Aging/ Printer Aging	
Print Report	Fax Confirm Transmit Log Receive Log Speed Dial List Self Test Protocol Dump ASF Test System Data NVRAM Dump CIS Pattern	
Maintenance	Cartridge Clean	
Program Download		
Message Confirm	On/Off/Error	On-Error
Remote RCV Code	(0-9)	9
EMC Mode	On/Off	On
Auto Reduction	Off/On/On-with vertical/	On
Retry Interval	(1-7)	3
Retry Count	(0-2)	2
Answer on Rings	(1-7)	1
Print RTI	Yes / No	
Modem Test	FSK/2400/4800/7200/ 9600/1200/14400 bps/ 1100/1650/1850/2100 Hz	
DTMF Test		

4400-001

Setup	Item	Default Status
ROM Test		
Modem Speed Item (1-6)	14400/12000/9600/ 7200/4800/2400	14400 bps
Set TX Level	(1-15)	12
Set RX Level	(40-50)	43
Pause Time	(1-9)	3

CIS Test

The test adjusts the light of CIS. It is already set at CIS Test to get optimum quality.

Warning: Shading profile must be made after downloading a new firmware. If not, system will not work properly.

1. Load all white document in scanner unit.
2. Press Setup and 'CIS Test Press Start' is displayed.
3. Press Start and 'Shading...' is displayed.
4. After scanning, shading waveform is printed.
5. After shading waveform has printed, press Stop.
6. Turn Off system and turn On.

Aging Test

Scanner Aging - Scanner part aging
Printer Aging - Printer part aging.

Print Report

1. Press Setup.
2. Press Menu until 'Print Report' is displayed.
3. Press Options to select the log you want to print.
4. Press Start or Setup to print the report.

Maintenance

1. Press Setup.
2. Press Menu until 'Maintenance' displays.
3. Press Options button to select, cartridge clean, cartridge align and scanner init.
4. Press Start after you select.

Program Download

1. Press Setup.
2. Press Menu four times until 'Program Download Press Start' is displayed.
3. Press Start.
4. Download your new firmware files from PC.

Note: Be sure the USB cable is connected to the PC when you are running this test. If cable is not connected, it may cause a fatal error.

Message Confirm

A message confirmation report shows whether the transmission was successful or not and how many pages were sent.

1. Press Setup.
2. Press Menu five times until 'Message Confirm, Report, On Report, Off Report, Error' is displayed.
3. Press Options to print a confirmation report automatically each time you send a fax (On). Press Options to turn this feature Off. Press Options to print only when an error occurs and the transmission was not successful. Press Start or Setup to set the time you want to select.

Remote RCV Code

The remote receive code lets you initiate fax received from an extension phone plugged into the EXT jack. If you pick up the extension phone and hear fax tones, enter the remote receive code and the fax starts receiving. The password is preset to 9.

1. Press Setup.
2. Press Menu until 'Remote RCV Code' displays on the top line.
3. Enter the desired code 0 to 9 on the number keypad.

ECM (Error Correction Mode)

This mode compensates for poor line quality and ensures accurate, error-free transmission with another ECM-equipped facsimile machine. If the line quality is poor, transmission time may be increased when ECM is enabled.

1. Press Setup.
2. Press Menu until 'ECM Mode' displays.
3. Press Start or Setup when Yes is displayed to turn on the Error Correction Mode. Press Start or Setup when No is displayed to turn off the Error Correction Mode.

Auto Reduction

When receiving a document as long or longer than the paper installed in your machine, the machine can reduce the data in the document to fit into your recording paper size.

Turn on this feature if you want to reduce an incoming page that may otherwise need to be divided into two pages with only a small portion on the second page. If the fax machine cannot reduce the data to fit one page with the feature enabled, the data is divided and printed in actual size on two or more sheets.

1. Press Setup.
2. Press Menu until 'Auto Reduction' displays. To turn only the vertical reduction feature On, press Start or Setup when On is displayed. The machine reduces an incoming page containing overflow data only in vertical. Press Start or Setup when Off is displayed to turn this feature on.

Retry Interval

1. Press Setup.
2. Press Menu until 'Retry Interval' displays.
3. Enter the number of minutes (from 1 to 7) using the numbers on the keypad.

Retry Count

1. Press Setup.
2. Press Menu until 'Retry Count' displays.
3. Enter the number of attempts (from 1 to 2) to redial the number. If you enter 0, the machine will not redial.

Answer On Rings

You can select the number of times your machine rings before answering an incoming call. If you are using your machine as both a telephone and a fax machine, we suggest you set the ring count to at least 4 to give you time to answer.

1. Press Setup.
2. Press Menu until 'Answer On Rings' displays.
3. Enter a number from 1 through 7 on the keypad.

Print RTI (Receive Terminal ID)

This feature lets the machine automatically print the receive terminal ID (if registered), page number, and the date and time of the reception at the bottom of each page on the received document.

1. Press Setup.
2. Press Menu until 'Print RTI' displays.
3. Press 1 to print RTI, otherwise press 2.

4400-001

Modem Test

The modem sends various transmit signals on the telephone line. You can check the following:

- FSK
 - Tones: 1100Hz, 1650Hz, 1850Hz, 2100Hz
 - G3 training: 14400, 12000, 9600, 7200, 4800, 2400 bps
1. Press Setup.
 2. Press Menu until 'Modem Test' displays.

DTMF Test

This feature the user or tester verify that the phone keypad buttons are working correctly.

1. Press Setup.
2. Press Menu until "DTMF Test" displays.
3. Press Start.

To test each button, press each button one at a time. There is a different tone for each button. Each pressed button displays a corresponding number or symbol in the LCD panel. If any button fails, replace the operator panel.

Modem Speed

Default=14400 bps

Select baud rate of 14400, 12000, 9600, 7200, 4800 or 2400 bps. The lower the baud rate, the larger the acceptable error rate. T30 protocol has a fixed speed of 300 bps in the protocol mode. When the TX speed is set to 14400 or 12000 bps, the RX speed will be either V.17 or V.33. When the TX speed is set to 9600 or 7200 bps, the RX speed will be either V.29 or V.27. When the TX speed is set to 4800 or 2400 bps, the RX speed will be V.27.

1. Press Setup.
2. Press Menu until 'Modem Speed' displays.
3. Press Options to select the TX speed you want. Then press Start or Setup.

Set TX Level

Default=12 dBm

FCC requires that the transmission level be less than -9 dBm. From -9 dBm to -15 dBm is acceptable. You can set the transmission level between 0 and -15 dBm in 1 dBm steps using the operator panel keypad. Accuracy is +0/-3 dBm.

1. Press Setup.
2. Press Menu until 'Set TX Level' displays.
3. Enter a number from 1 through 15 on the keypad.

Set RX Level

Default=-43 dBm

Reception level may be too low due cable losses. If set to -43 dBm, reception sensitivity will be between 0 and -43 dBm.

1. Press Setup.
2. Press Menu until 'Set RX Level' displays.
3. Enter a number from 40 through 50 on the keypad.

Pause Time

Default=3 seconds

This sets the length of the pause time from 1 through 9 seconds.

1. Press Setup.
2. Press Menu until 'Pause Time' displays.
3. Enter a number from 1 through 9 on the keypad.

4. Repair Information

This chapter explains how to make adjustments to the printer and how to remove defective parts.

Note: Read the following before handling electronic parts.

Handling ESD-Sensitive Parts

Many electronic products use parts that are known to be sensitive to electrostatic discharge (ESD). To prevent damage to ESD-sensitive parts, follow the instructions below in addition to all the usual precautions, such as turning off power before removing logic boards:

- Keep the ESD-sensitive part in its original shipping container (a special “ESD bag”) until you are ready to install the part into the machine.
- Make the least-possible movements with your body to prevent an increase of static electricity from clothing fibers, carpets, and furniture.
- Put the ESD wrist strap on your wrist. Connect the wrist band to the system ground point. This discharges any static electricity in your body to the machine.
- Hold the ESD-sensitive part by its edge; do not touch its pins. If you are removing a pluggable module, use the correct tool.
- Do not place the ESD-sensitive part on the machine cover or on a metal table; if you need to put down the ESD-sensitive part for any reason, first put it into its special bag.
- Machine covers and metal tables are electrical grounds. They increase the risk of damage because they make a discharge path from your body through the ESD-sensitive part. (Large metal objects can be discharge paths without being grounded.)
- Prevent ESD-sensitive parts from being accidentally touched by other personnel. Install machine covers when you are not working on the machine, and do not put unprotected ESD-sensitive parts on a table.
- If possible, keep all ESD-sensitive parts in a grounded metal cabinet (case).
- Be extra careful in working with ESD-sensitive parts when cold weather heating is used because low humidity increases static electricity.

Adjustments

The user is directed, in the Printer Control program, to perform the bidirectional alignment adjustments after replacing a print cartridge.

Removal Procedures

The following procedures are arranged according to the name of the printer part discussed.

CAUTION: Unplug the power cord before removing any parts.

Releasing Plastic Latches

Many of the parts are held in place with plastic latches. The latches break easily; release them carefully. To remove such parts, press the hook end of the latch away from the part to which it is latched.

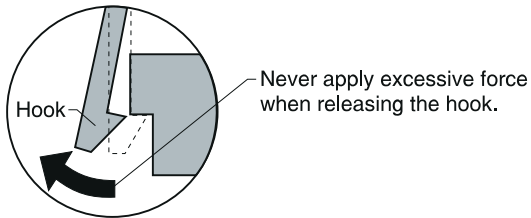

Removals

General Precautions on Removals

When you disassemble and reassemble components, use extreme caution. The close proximity of cables to moving parts makes proper routing a must. If components are removed or replaced, any cables disturbed must be replaced as close as possible to their original positions. Before removing any component from the machine, note the cable routing.

When servicing the machine:

1. Check to verify that documents are not stored in memory.
2. Move the printer cartridge to far right to cap the nozzle.
3. Unplug the power cord.
4. Use a flat and clean surface.
5. Replace only with authorized components.
6. Do not force plastic-material components.
7. Make sure all components are in their proper position.

CIS White Roller Assembly Removal

1. Open the operator panel.
2. Push the bushing on both ends of the roller slightly inward, then rotate it until it reaches the slot as shown. Then lift the roller out.

Note: Check the roller for any dirt. If dirty, wipe it off with soft cloth dampened with water. If the roller is heavily worn, replace it with a new one.

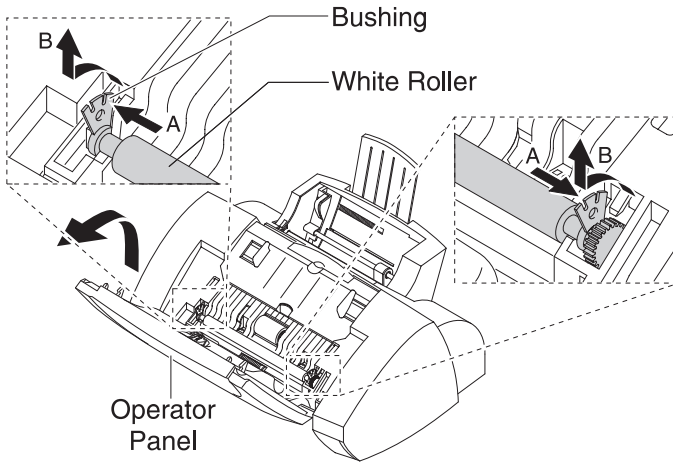

Top Cover Assembly Removal

1. Open the operator panel and open the print cartridge compartment cover. Remove the white roller assembly. Remove the six screws as shown.

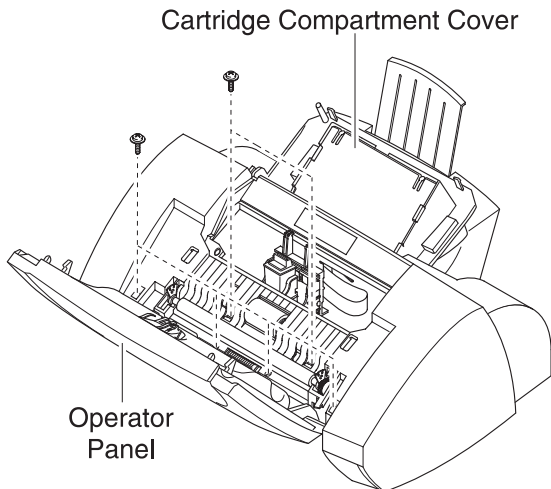

2. Remove the three screws as shown and remove the top cover assembly.

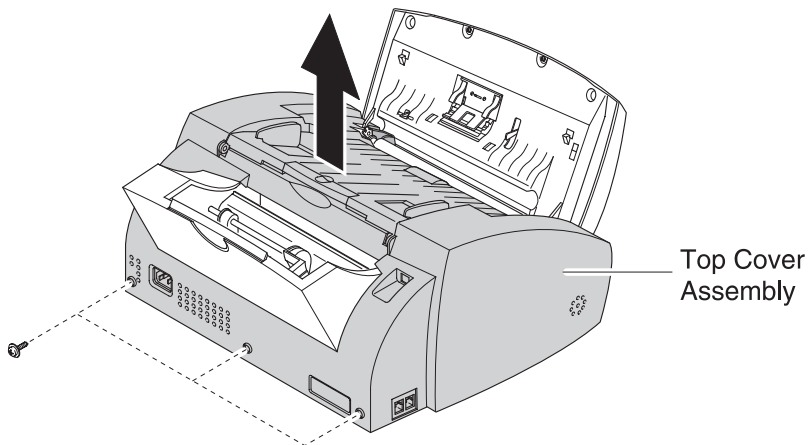

Rollers (Drive Feed Roller Assembly, Exit Shaft) Removal

1. Remove the top cover assembly. See **“Top Cover Assembly Removal”** on page 4-5.
2. Take out the rollers from the base assembly.

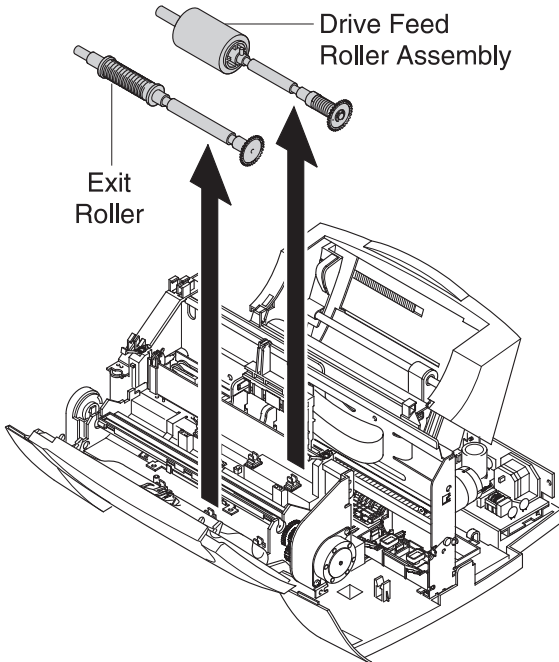

Note: Clean the surface of the rollers with ethyl alcohol. After wiping them, you must dry them completely.

CIS (Contact Image Sensor) Removal

1. Remove the top cover assembly. See **“Top Cover Assembly Removal”** on page 4-5.
2. Remove the drive feed roller. See **“Rollers (Drive Feed Roller Assembly, Exit Shaft) Removal”** on page 4-6.
3. Remove one screw securing the CIS assembly and unplug the CIS harness. Remove the CIS assembly.

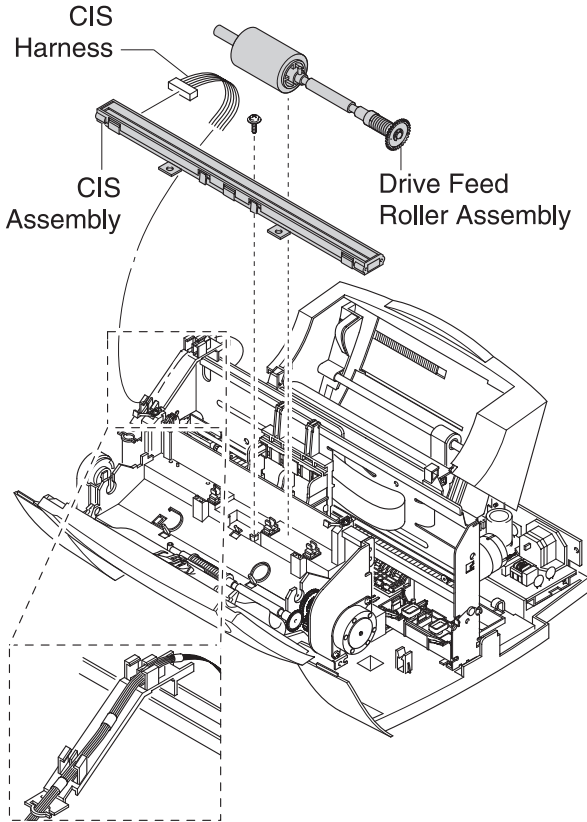

4400-001

4. Turn the CIS assembly over. Remove one screw to release the CIS from the bracket

Note: Be careful not to lose the springs.

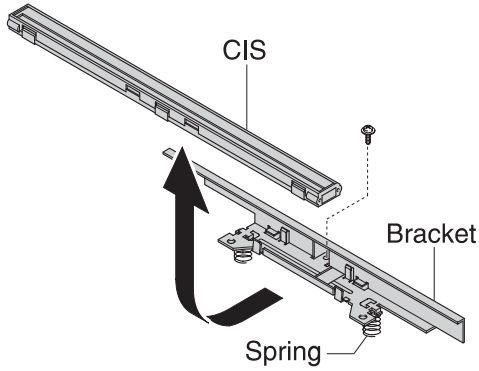

Note: Check the glassy surface of the CIS for any stain or scratch. If stained, wipe off with ethyl alcohol. If it is heavily stained or scratched, replace it.

Scanner Motor with Gear Assembly Removal

1. Remove the top cover assembly. See **“Top Cover Assembly Removal”** on page 4-5.
2. Unplug the motor connector from the system board. Make sure the harness is released from hooks securing the harness as shown.

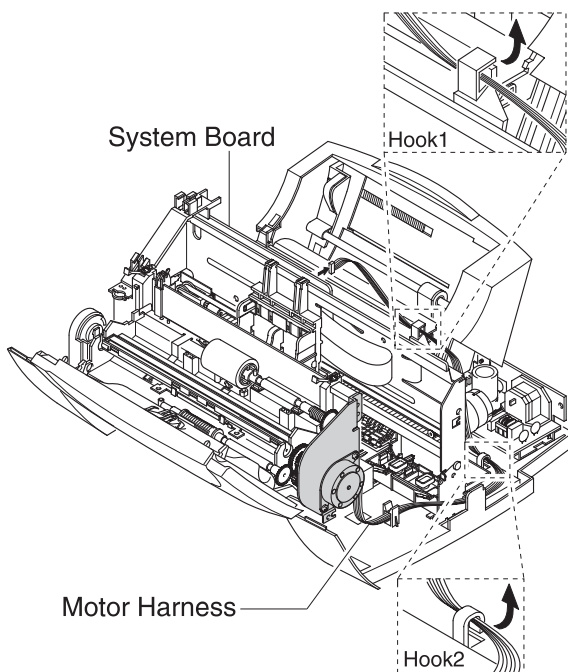

3. Remove two screws as shown and remove the scan motor assembly.

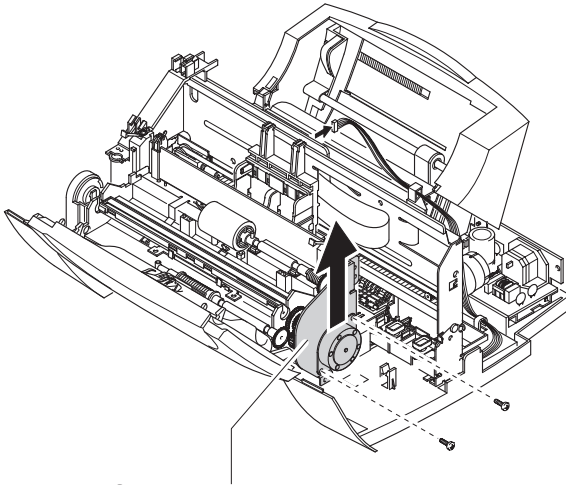

Scan Motor Assembly

4. Remove the two screws securing the motor to the motor bracket.

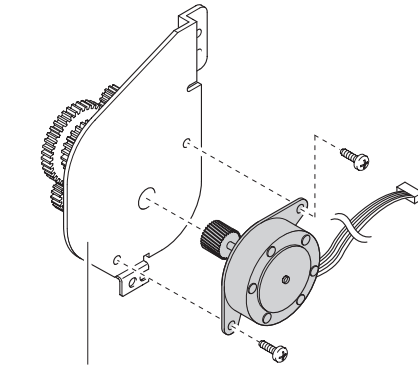

Motor Bracket

Power Supply Removal

1. Remove the top cover assembly. See **“Top Cover Assembly Removal”** on page 4-5.
2. Unplug the power supply connector from the system board. Make sure the harness is released from the hook as shown.

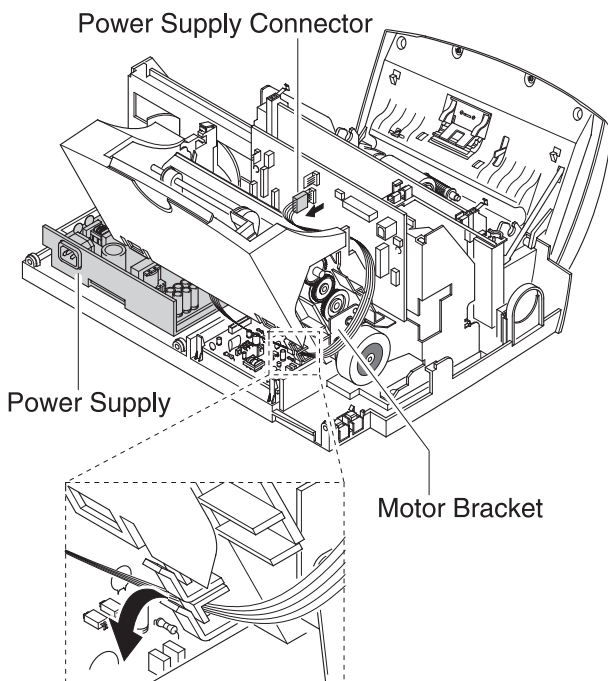

3. Remove one screw securing the ground wires to the bracket.

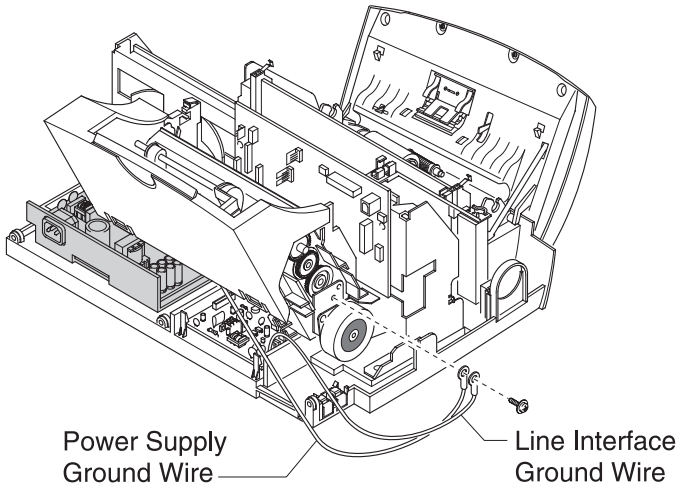

4. Push down on the hooks on both ends and remove the power supply.

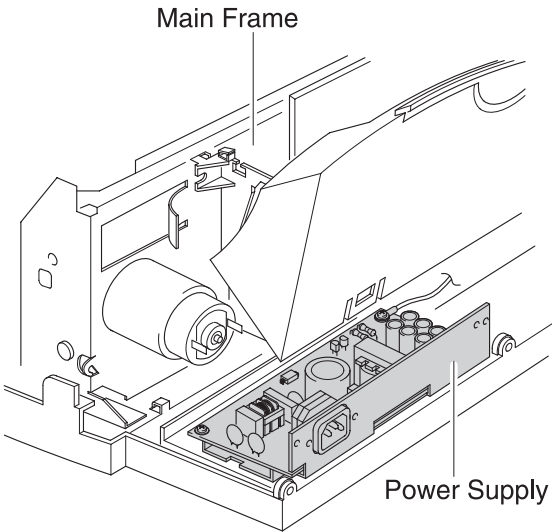

Line Interface Board Removal

1. Remove the top cover assembly. See **“Top Cover Assembly Removal”** on page 4-5.
2. Remove the one screw securing the ground wires to the bracket.

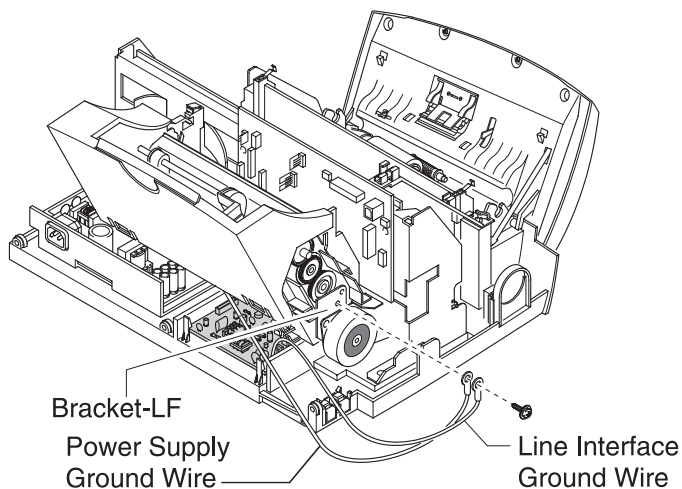

3. Unplug the line interface connector from the system board.

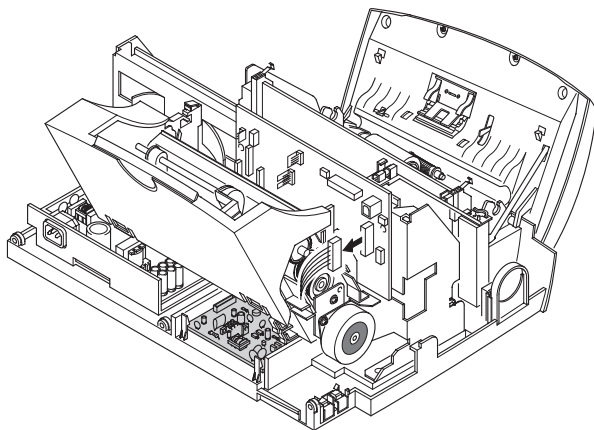

4. Pull the snap as shown to unlock the line interface board from the system board. Push up on the line interface board.

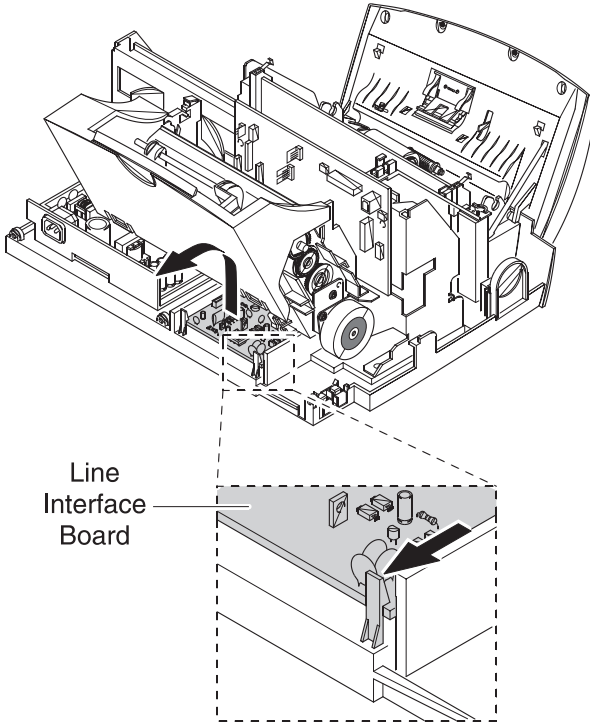

5. Unplug all the connectors from the line interface board and remove it.

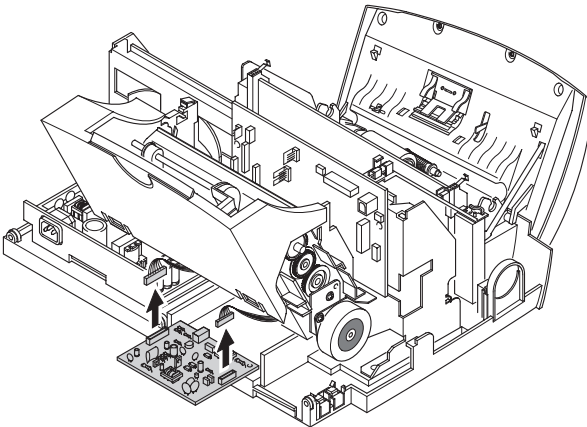

Operator Panel Assembly Removal

1. Remove the top cover assembly. See **“Top Cover Assembly Removal”** on page 4-5.
2. Disconnect the operator panel cable from the system board.
3. Release harness from harness hook.
4. Remove the two ground strap screws.
5. Turn the tie stopper 90 degrees as shown and remove from operator panel assembly.
6. Release ground strap cable hooks.
7. Release opposite operator panel hinge.

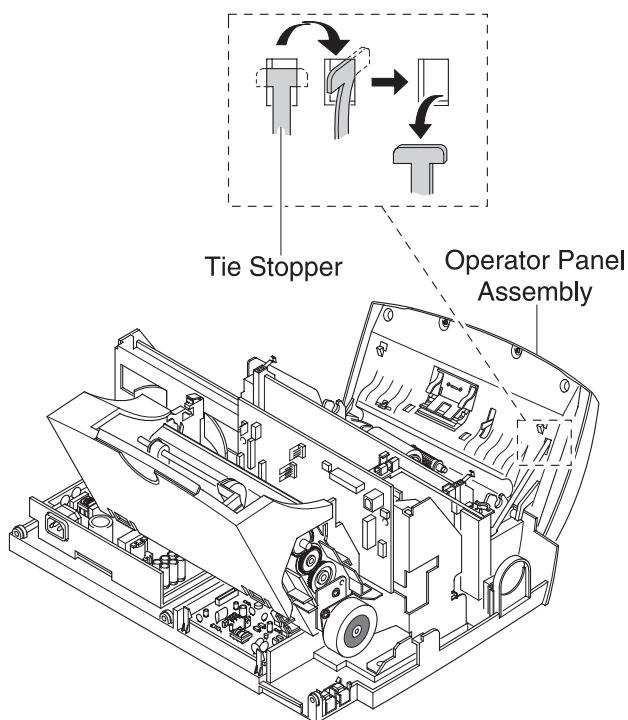

Printer Unit Removal

1. Remove the top cover assembly. See **“Top Cover Assembly Removal”** on page 4-5.
2. Remove the paper support extension.
3. Release lower paper guide tabs.
4. Release upper paper guide tab.
5. Remove the paper guide.
6. Remove the paper deflector.

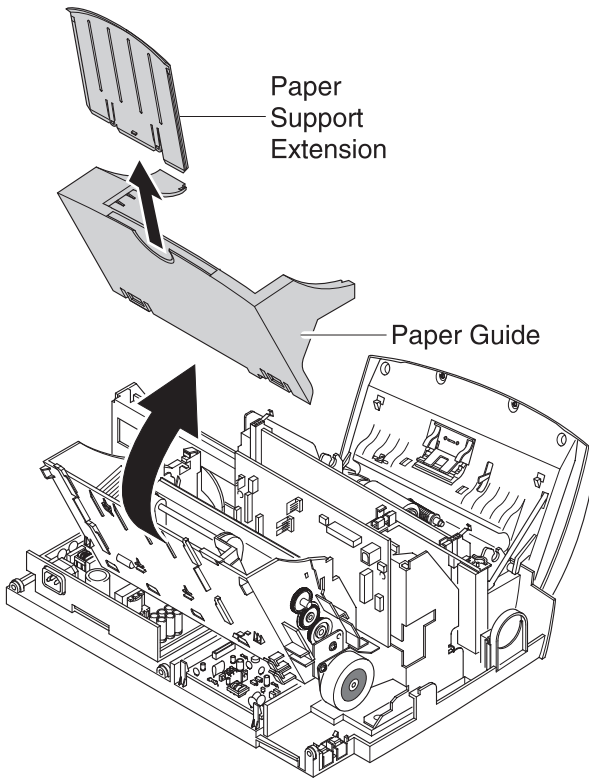

7. Remove three screws securing the printer unit, and unplug the eight connectors from the system board. Remove the printer unit.

8. Remove ground strap screw.

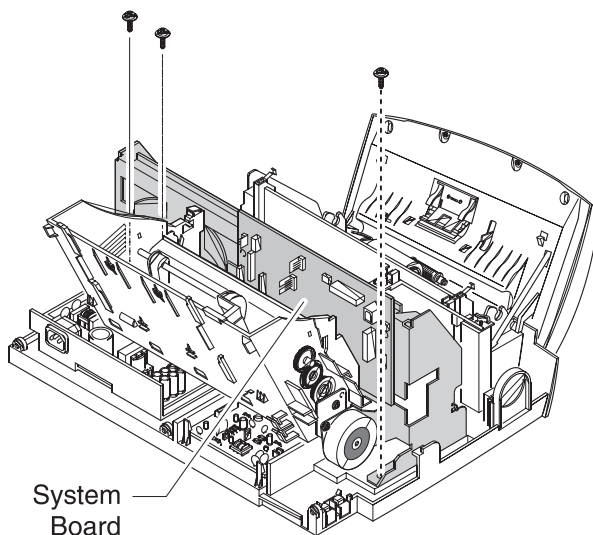

Note: When you reassemble the unit, do not pinch or short the wire harness.

ASF Assembly Removal

1. Remove the top cover assembly. See **“Top Cover Assembly Removal”** on page 4-5.
2. Remove paper support extension.
3. Release lower paper guide tabs.
4. Release upper paper guide tab.
5. Remove paper guide.
6. Remove paper deflector.
7. Release cables from guides located on ASF assembly.
8. Remove two screws.
9. Push down on power supply hooks and slide the power supply away from printer.
10. Remove screw.

11.Remove ASF assembly.

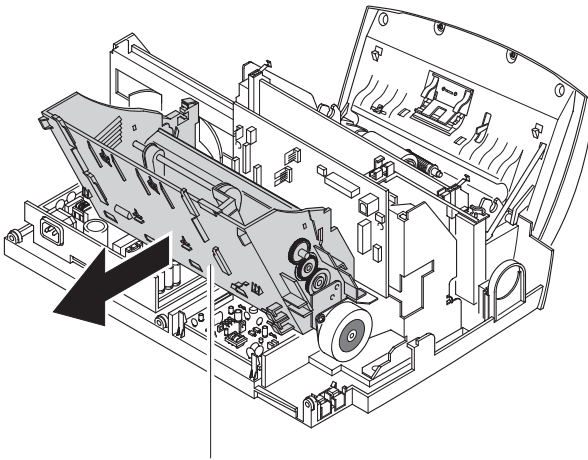
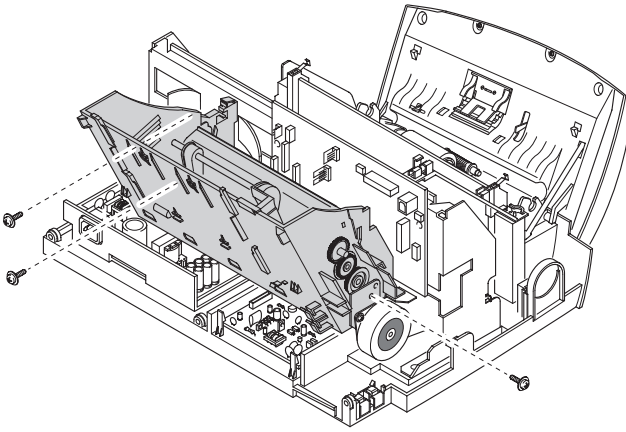

Automatic Sheet Feeder Assembly

Maintenance Station Removal

1. Remove the printer unit.
2. Remove one screw.
3. Release two tabs from the rear of the maintenance station and remove the maintenance station..

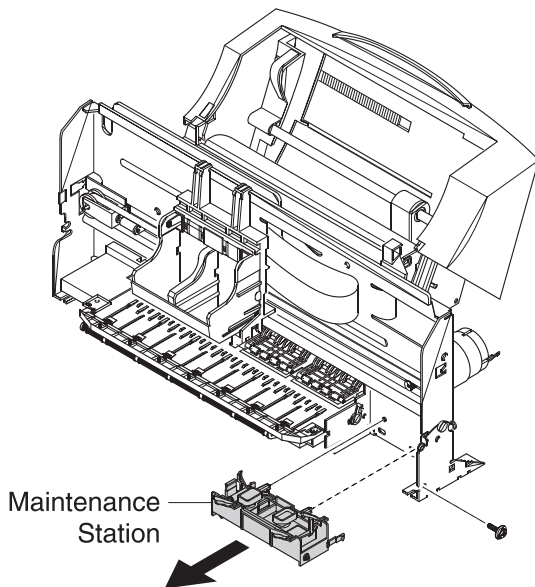

Carrier Assembly with Belt Removal

1. Remove the printer unit. See **“Printer Unit Removal”** on **page 4-16**.
2. Disconnect the carrier cables from the system board.
3. Release tab on carrier cable guide.
4. Release carrier cable guide from frame.
5. Remove pulley stopper.
6. Depress the belt tensioner and remove the belt from the carrier motor.
7. Remove two carrier springs that secure the shaft.
8. Remove the carrier shaft.
9. Remove the carrier assembly.

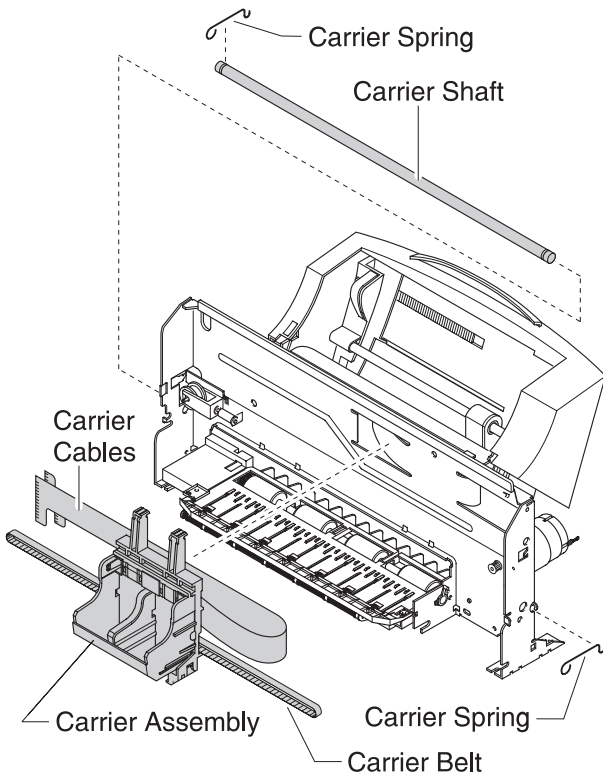

System Board Removal

1. Remove the top cover assembly. See **“Top Cover Assembly Removal”** on page 4-5.
2. Remove two screws securing the system board.
3. Unplug all connectors.
4. Pull the sensor lever toward you and remove the system board.

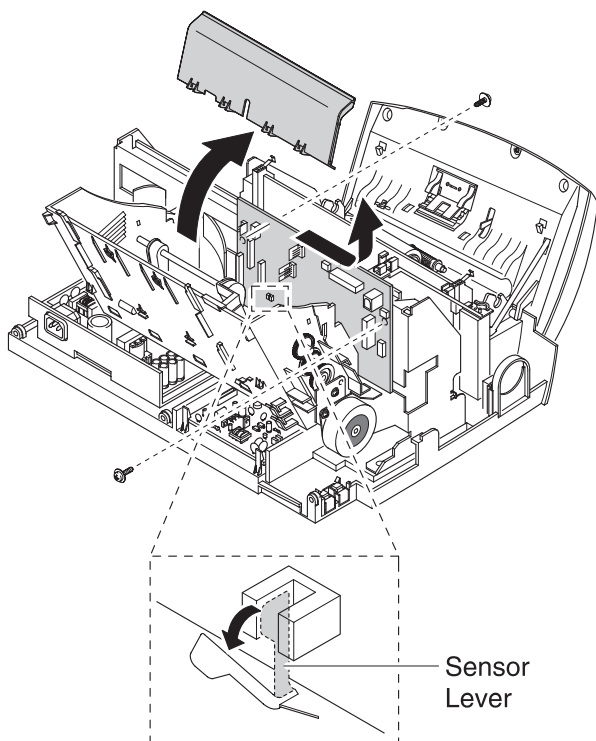

Mid Frame Assembly with Exit Rollers Removal

1. Remove the top cover.
2. Remove the carrier assembly.
3. Remove the maintenance station.
4. Remove the encoder strip.
5. Remove two screws from friction roller assembly.
6. Remove exit roller assembly.
7. Release four springs on small feed roller assembly.
8. Press down and remove each section of lower portion of small feed roller assembly.
9. Release tabs in upper portion of small feed roller assembly.
10. Remove upper portion of small feed roller assembly.
11. Push up on mid frame assembly to release from large feed roller.
12. Remove mid frame assembly.

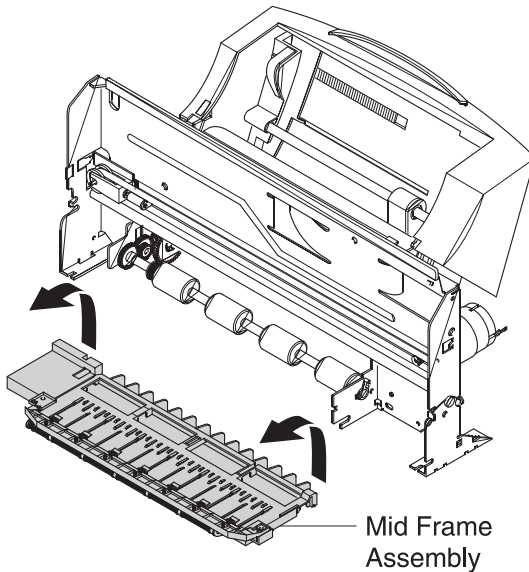

Large Feed Roller Assembly with Gear Removal

1. Remove the printer unit. See **“Printer Unit Removal”** on page 4-16.
2. Remove the mid frame assembly. See **“Mid Frame Assembly with Exit Rollers Removal”** on page 4-22.
3. Remove the maintenance station.
4. Remove the feed roller bearing from the main frame. Pull the feed roller as shown and remove.

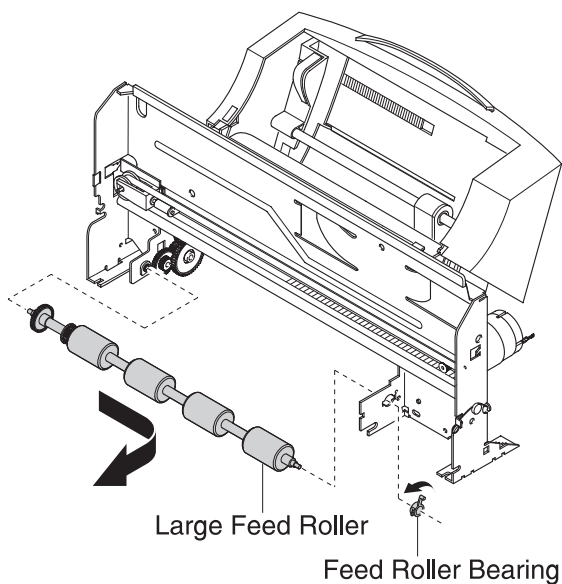

Paper Feed Motor Assembly with Gears Removal

1. Remove the printer unit. See **“Printer Unit Removal”** on page 4-16.
2. Remove the large feed roller assembly. See **“Large Feed Roller Assembly with Gear Removal”** on page 4-23.
3. Remove the two screws and remove the paper feed motor assembly.

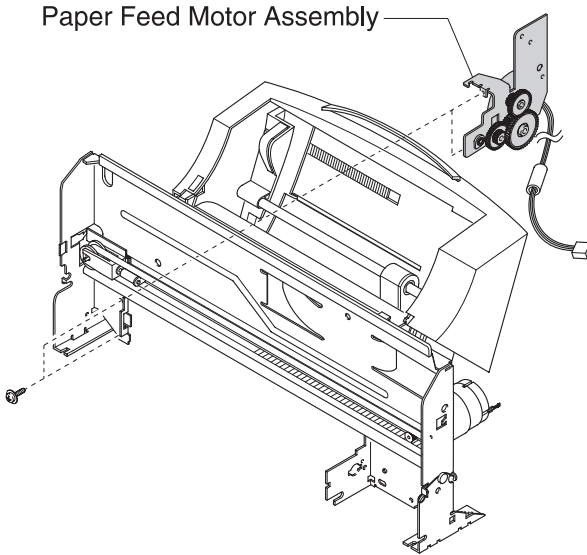

Carrier Transport Motor Removal

1. Remove the top cover assembly. Go to the **“Top Cover Assembly Removal” on page 4-5.**
2. Manually move the carrier to the center of the machine.
3. Remove the idler pulley assembly spring cover retainer.
4. Press the idler pulley and remove the belt from the carrier transport pulley.
5. Disconnect connector (CN5) from the system board.
6. Remove the two screws from the carrier transport motor and remove.

4400-001

5. Connector Locations

System Board

Units	Description
CN5	Carrier Motor
CN8	Scanner Motor
CN10	Power Supply
CN11	Paper Feed Motor
CN12	Door Switch
CN13	CIS
CN15	Line Interface Board
CN16	Speaker
CN17	Operator Panel

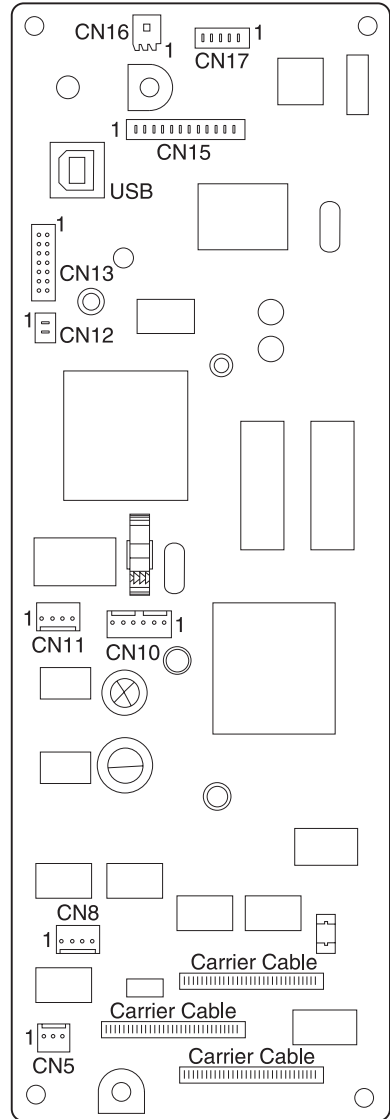

Logic Card

Units	Description
P1	System Board
P2	Phone Lines

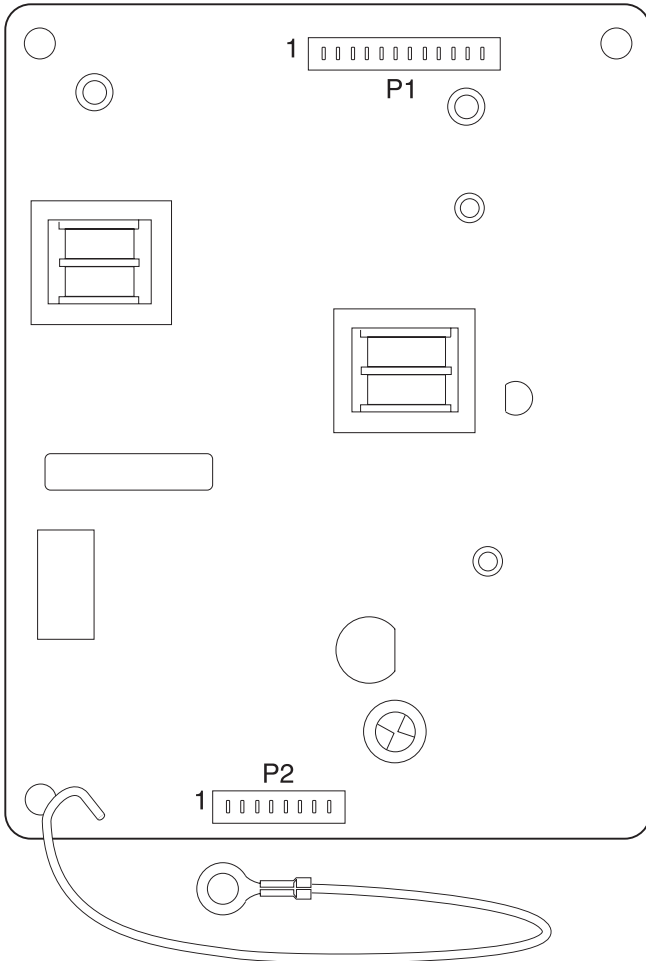

Power Supply

Units	Description
J5	System Board

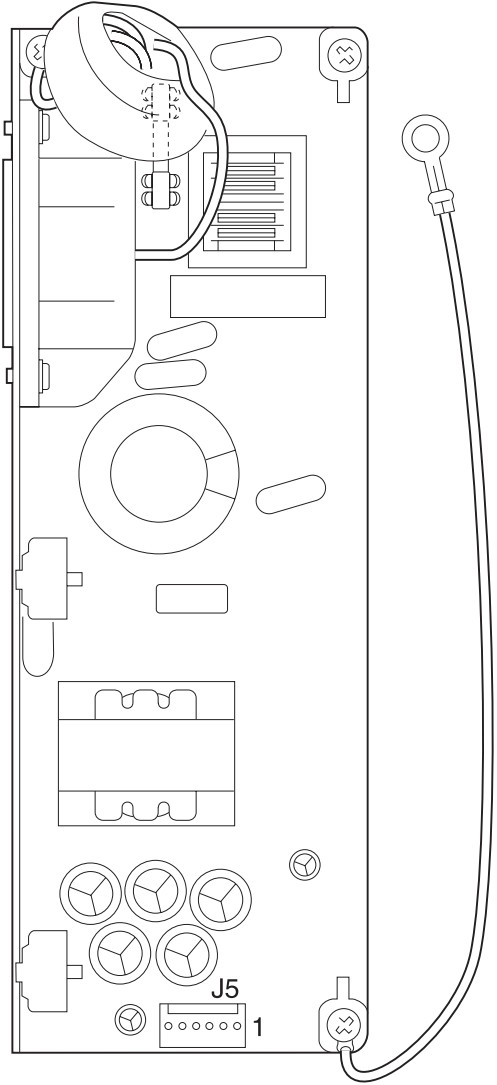

4400-001

6. Preventive Maintenance

This chapter contains the lubrication specifications. Follow these recommendations to prevent problems and maintain optimum performance.

Lubrication Specifications

Lubricate only when parts are replaced or as needed, not on a scheduled basis. Use grease P/N 99A0394 to lubricate the following:

- All gear mounting studs.
- The left and right ends of the large feed roller at the side frames.
- The carrier to carrier frame engagement.
- The carrier guide rod, and carrier guide rod bearings.

4400-001

7. Parts Catalog

How to Use This Parts Catalog

- **SIMILAR ASSEMBLIES:** If two assemblies contain a majority of identical parts, they are shown on the same list. Common parts are shown by one index number. Parts peculiar to one or the other of the assemblies are listed separately and identified by description.
- **NS:** (Not Shown) in the Asm-Index column indicates that the part is procurable but is not pictured in the illustration.
- **PP:** in the parts description column indicates the part is available in the listed parts packet.
- **NA:** Not available as a FRU

Assembly 1: Main Assembly

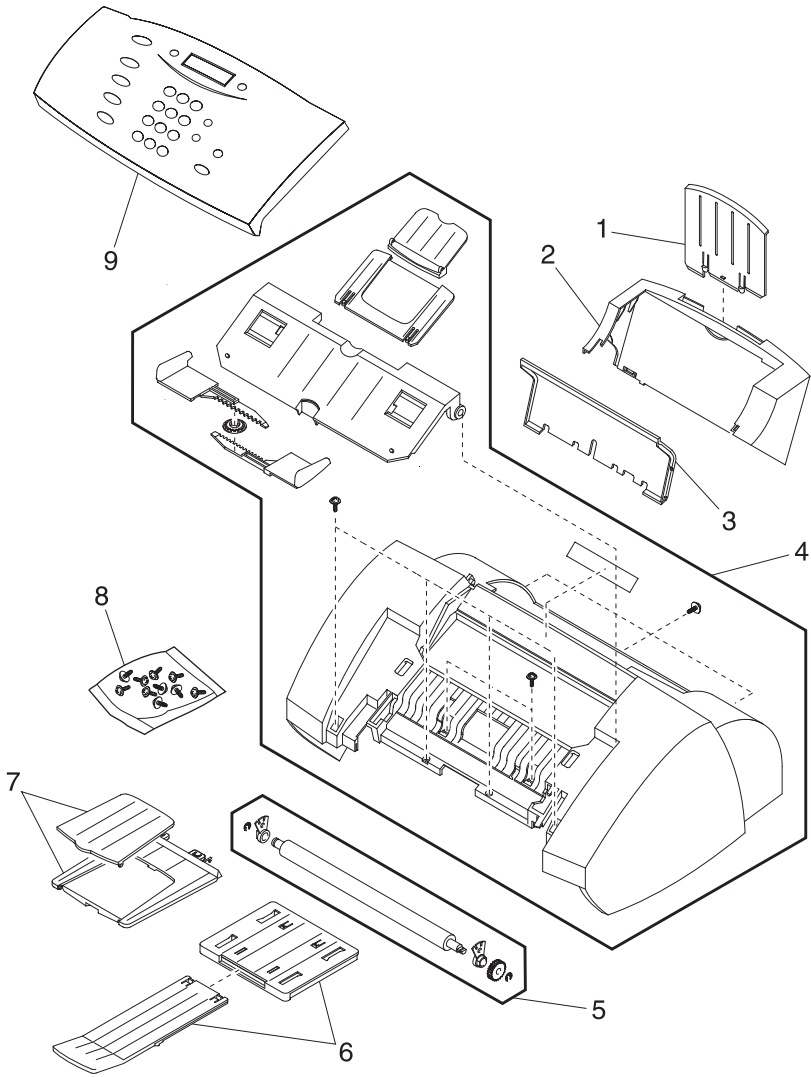

Assembly 1: Main Assembly

Asm-Index	Part Number	Units	Description
1	12G6933	1	Support, Paper Extension
2	12G6932	1	Guide, Paper
3	12G6931	1	Deflector, Paper
4	12G6935	1	Cover, Top Assembly
5	12G6934	1	CIS White Roller Assembly
6	12G6936	1	Tray, Paper Exit Assembly
7	12G6937	1	Tray, Scan Exit Assembly
8	12G6938	1	Screw Parts Packet
9	12G6939	1	Panel, Operator Assembly
N/S	12G6973	1	Carrier Sheet

Assembly 2: Base Unit

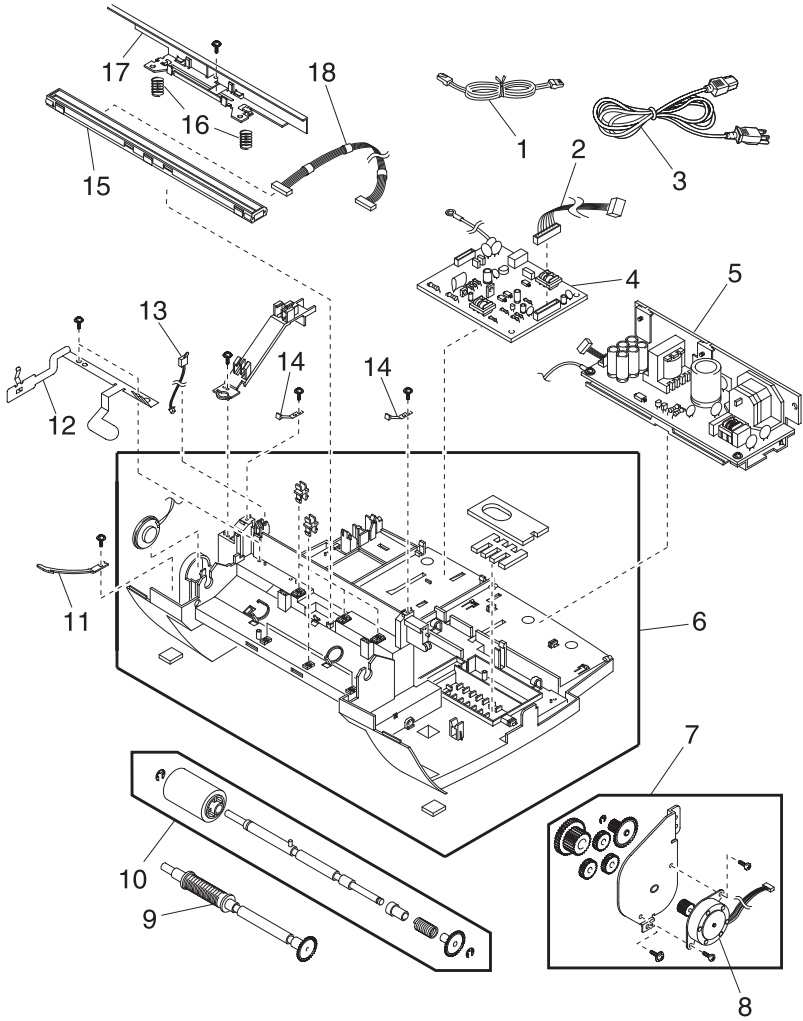

Assembly 2: Base Unit

Asm-Index	Part Number	Units	Description
1	12G6972	1	Phone Line Cord
2	12G6954	1	Cable, Line Interface Board
3	12G6971	1	Power Line Cord
4	12G6951	1	Board, Line Interface
5	12G6952	1	Power Supply
6	12G6940	1	Base Assembly
7	12G6946	1	Motor, Scanner with Gear Assembly
8	12G6947	1	Motor, Carrier Assembly
9	12G6948	1	Shaft, Exit
10	12G6941	1	Drive Feed Roller Assembly
11	12G6949	1	Strap, Operator Panel Door
12	12G6950	1	Spring, Ground
13	12G6979	1	Sensor, Access Door
14	12G6953	1	Latch, Operator Panel Door
15	12G6942	1	Contact, Image Sensor (CIS)
16	12G6944	1	Spring, CIS
17	12G6945	1	IPR-Bracket CIS
18	12G6943	1	Cable. CIS

Assembly 3: Engine

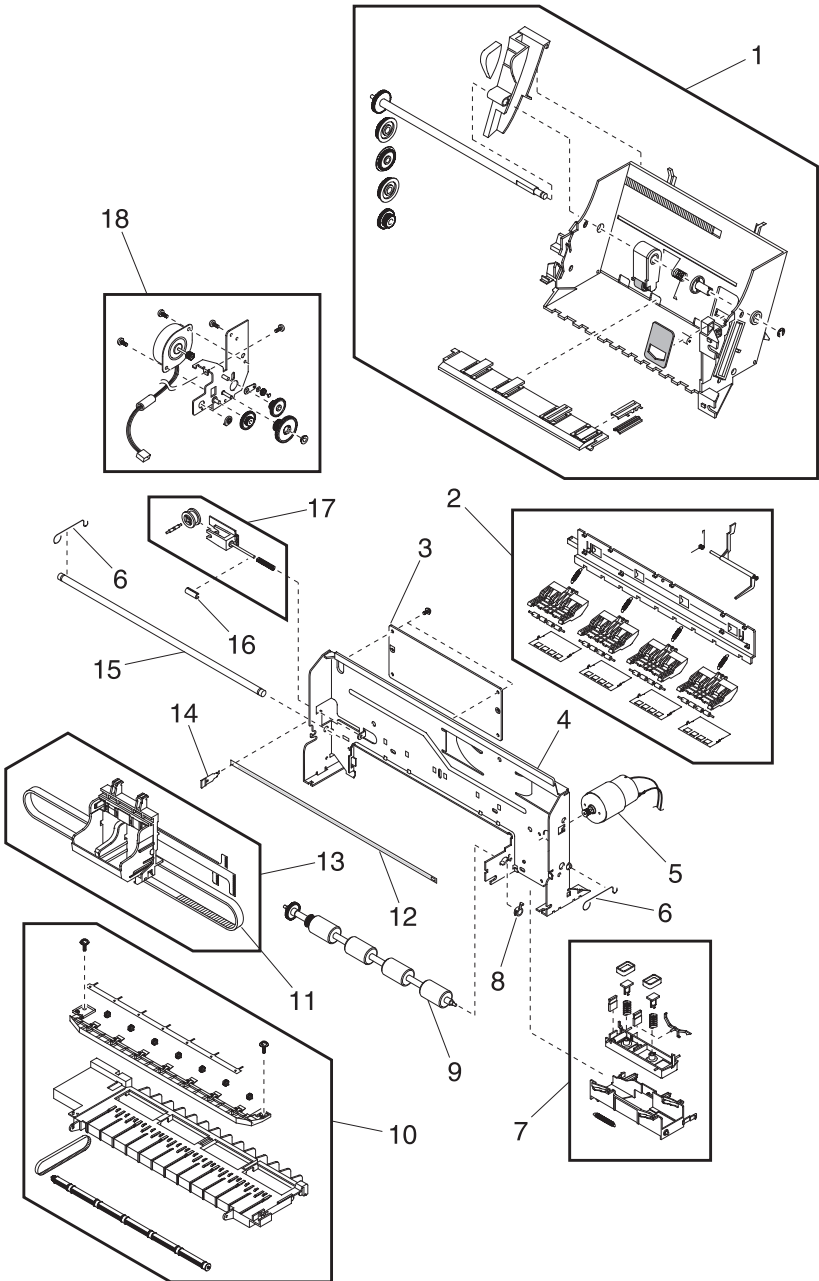

Assembly 3: Engine

Asm-Index	Part Number	Units	Description
3-1	12G6955	1	ASF Assembly
2	12G6961	1	Small Feed Roller Assembly with EOF and Springs
3	12G6970	1	System Board
4	12G6969	1	Main Frame Assembly with Encoder Clip
5	12G6959	1	Motor, Carrier Transport
6	12G6965	1	Spring, Carrier Shaft Retainer
7	12G6956	1	Maintenance Station Assembly
8	12G6966	1	Bearing, Feed Roller
9	12G6962	1	Feed Roller, Large with Gear
10	12G6964	1	Frame, Mid Assembly with Exit Rollers
11	12G6980	1	Carrier Belt
12	12G6968	1	Strip, Encoder
13	12G6960	1	Carrier Assembly with Belt
14	12G6969	1	Main Frame Assembly with encoder clip
15	12G6967	1	Shaft, Carrier
16	12G6958	1	Stopper Pulley
17	12G6957	1	Pulley, Idle Assembly
18	12G6963	1	Motor, Paper Feed Assembly with Gears

4400-001

Index

A

Abbreviations 1-5
 Adjustments 4-2
 Aging Test 3-5
 Answer On Rings 3-8
 Auto Reduction 3-7

C

CIS Test 3-5
 Connector Locations 5-1

D

Diagnostic Aids 3-1
 Diagnostic Information 2-1
 DTMF Test 3-9

E

ECM 3-7
 ESD-Sensitive Parts 4-1

G

General Information 1-1

L

Logic Card 5-2
 Lubrication Specifications 6-1

M

Maintenance 3-6
 Message Confirm 3-6
 Modem Speed 3-9
 Modem Test 3-9

P

Parts Catalog 7-1
 Pause Time 3-10
 Plastic Latches 4-2
 POST 2-1
 Preventive Maintenance 6-1
 Print Report 3-5
 Print RTI 3-8

Problems

Carrier Transport 2-3
 Maintenance Station 2-3
 Operator Panel 2-3
 Paper Feed 2-6
 Power 2-6
 Print Quality 2-6
 Printer Communication 2-5
 Scanner 2-5

Program Download 3-6

R

Remote RCV Code 3-7
 Removal Procedures 4-2

Removals

ASF Assembly 4-17
 Carrier Assembly 4-20
 Carrier Transport Motor 4-25
 CIS White Roller 4-4
 Contact Image Sensor 4-7
 Large Feed Roller 4-23
 Line Interface Board 4-13
 Maintenance Station 4-19
 Mid Frame Assembly 4-22
 Operator Panel 4-15
 Paper Feed Motor 4-24
 Power Supply 4-11
 Printer Unit 4-16
 Rollers 4-6
 Scanner Motor 4-9
 System Board 4-21
 Top Cover Assembly 4-5

Repair Information 4-1

Retry Count 3-8
 Retry Interval 3-8

S

Safety Information v
 Service Checks
 Carrier Transport 2-7
 CIS Assembly 2-9
 Fax/Telephone Communication
 2-19

4400-001

Maintenance Station	2-11	12G6946	7-5
Paper Feed	2-12	12G6947	7-5
Paper Path	2-14	12G6948	7-5
Power	2-15	12G6949	7-5
Print Quality	2-16	12G6950	7-5
Scan/Copy Quality	2-18	12G6951	7-5
Scanner Motor	2-10	12G6952	7-5
Service Mode	3-2, 3-4	12G6953	7-5
Set RX Level	3-10	12G6954	7-5
Set TX Level	3-10	12G6955	7-7
Specifications		12G6956	7-7
Facsimile	1-3	12G6957	7-7
Power and Size	1-5	12G6958	7-7
Printer Engine	1-2	12G6959	7-7
Printhead	1-2	12G6960	7-7
Scanner	1-5	12G6961	7-7
Symptom Table (POST)	2-2	12G6962	7-7
Symptom Tables	2-3	12G6963	7-7
System Board	5-1	12G6964	7-7
		12G6965	7-7
		12G6966	7-7
		12G6967	7-7
		12G6968	7-7
		12G6969	7-7
		12G6970	7-7
		12G6971	7-5
		12G6972	7-5
		12G6979	7-5
		12G6980	7-7
T			
Theory of Mechanism			
Contact Image Sensor	3-2		
Document Sensors	3-2		
Drive Feed Roller Assembly	3-1		
Scanner	3-1		
U			
User Mode	3-3		

Part Numbers

12G6931	7-3
12G6932	7-3
12G6933	7-3
12G6934	7-3
12G6935	7-3
12G6936	7-3
12G6937	7-3
12G6938	7-3
12G6939	7-3
12G6940	7-5
12G6941	7-5
12G6942	7-5
12G6943	7-5
12G6944	7-5
12G6945	7-5