



Service Manual

Lexmark X215 MFP

4038-001

- ***Table of Contents***
- ***Start Diagnostics***
- ***Safety and Notices***
- ***Trademarks***
- ***Index***

LEXMARK™

Lexmark and Lexmark with diamond design are trademarks of Lexmark International, Inc., registered in the United States and/or other countries.

Edition: June 2003

The following paragraph does not apply to any country where such provisions are inconsistent with local law: LEXMARK INTERNATIONAL, INC. PROVIDES THIS PUBLICATION "AS IS" WITHOUT WARRANTY OF ANY KIND, EITHER EXPRESS OR IMPLIED, INCLUDING, BUT NOT LIMITED TO, THE IMPLIED WARRANTIES OF MERCHANTABILITY OR FITNESS FOR A PARTICULAR PURPOSE. Some states do not allow disclaimer of express or implied warranties in certain transactions; therefore, this statement may not apply to you.

This publication could include technical inaccuracies or typographical errors. Changes are periodically made to the information herein; these changes will be incorporated in later editions. Improvements or changes in the products or the programs described may be made at any time.

Comments may be addressed to Lexmark International, Inc., Department D22A/032-2, 740 West New Circle Road, Lexington, Kentucky 40550, U.S.A or e-mail at ServiceInfoAndTraining@Lexmark.com. Lexmark may use or distribute any of the information you supply in any way it believes appropriate without incurring any obligation to you. You can purchase additional copies of publications related to this product by calling 1-800-553-9727. In other countries, contact your point of purchase.

Lexmark, and Lexmark with diamond design are trademarks of Lexmark International, Inc., registered in the United States and/or other countries.

Other trademarks are the property of their respective owners.

© 2003 Lexmark International, Inc.

All rights reserved.

UNITED STATES GOVERNMENT RIGHTS

This software and any accompanying documentation provided under this agreement are commercial computer software and documentation developed exclusively at private expense.

Table of contents

Laser notices	vii
Safety information	xvii
Preface	xxii
Definitions	xxii
General information	1-1
Machine features	1-1
Print materials	1-2
Cleaning the machine	1-5
Cleaning the outside of the machine	1-5
Cleaning the inside of the machine	1-6
Cleaning the scan unit	1-8
Cleaning the photoconductor drum	1-9
Maintenance approach	1-9
Tools	1-9
Abbreviations	1-10
Diagnostic information	2-1
Start	2-1
Error message table	2-2
Symptom table	2-10
Paper feed problems	2-11
Printing and copying problems	2-13
Scanning problems	2-18
Faxing problems	2-19
Print quality checks	2-21
Service checks	2-30
Diagnostic aids	3-1
Configuration modes	3-1
Clear All Memory mode	3-1
Dial mode	3-2
Error Rate mode	3-2
Modem Speed mode	3-3
Park CCD module mode	3-4
Print Properties mode	3-5
Send Level mode	3-7
System Settings Report mode	3-7

Machine tests	3-8
DRAM Memory test	3-8
Modem Protocol Log test	3-9
Modem test	3-9
Motor, Fan, Solenoid test	3-10
Operator Panel Button test	3-11
Operator Panel test	3-12
Printhead test	3-13
Print Quality Pages test	3-14
ROM Memory test	3-15
Scanner CCD Module and Motor test	3-16
Sensor test	3-16
Customizing settings	3-18
Content	3-18
Darkness	3-19
Number	3-19
Scale	3-20
Advanced	3-21
Repair information	4-1
Removals	4-1
Covers	4-1
Automatic document feed (ADF) removals	4-16
CCD module assembly removal	4-18
Fan removal	4-30
Fuser removal	4-31
HVPS contact removal	4-32
LVPS / HVPS card removal	4-33
Main drive assembly removal	4-36
Main paper feed roller removal	4-38
Main feed roller solenoid removal	4-41
Manual paper feed sensor actuator removal	4-44
Modem card removal	4-46
Operator panel removal	4-49
Paper empty sensor actuator removal	4-51
Paper feed sensor actuator removal	4-53
Paper tray feed roller removal	4-55
Paper tray pick roller assembly removal	4-56
Paper tray solenoid removal	4-60
Printhead removal	4-62
Scanner assembly removal	4-63
Scanner card assembly removal	4-67
Scanner assembly cushion removal	4-70

Scanner assembly hinge removal.....	4-71
System board removal	4-72
Transfer roll removal	4-75
Locations	5-1
Front view	5-1
Rear view	5-2
EP rollers.....	5-3
Operator panel	5-4
HVPS / LVPS card	5-6
Modem card	5-8
Operator panel card	5-9
Scanner card	5-10
System board	5-12
ADF paper path	5-14
Printer engine paper path/paper jams.....	5-15
Preventive maintenance	6-1
Parts catalog	7-1
How to use this parts catalog	7-1
Assembly 1: Scanner assembly	2
Assembly 2: Main assembly.....	4
Assembly 3: Frame assembly	6
Index	I-1
Part number index	I-5

4038-001

Laser notices

The following laser notice labels may be affixed to this printer as shown.

Laser advisory label

With the middle cover removed, the laser advisory label is affixed to the top of the printhead.



CAUTION - INVISIBLE LASER RADIATION WHEN THIS COVER OPEN. DO NOT OPEN THIS COVER.

VORSICHT - UNSICHTBARE LASERSTRAHLUNG, WENN ABDECKUNG GEÖFFNET. NICHT DEM STRAHLEN AUSSETZEN.

ATTENTION - RAYONNEMENT LASER INVISIBLE EN CAS D'OUVERTURE. EXPOSITION DANGEREUSE AU FASCIAU.

ATTENZIONE - RADIAZIONE LASER INVISIBILE IN CASO DI APERTURA. EVITARE L'ESPOSIZIONE AL FASCIO.

PRECAUCIÓN - RADIACIÓN LASER INVISIBLE CUANDO SE ABRE. EVITAR EXPONERSE AL RAYO.

PERIGO - RADIAÇÃO LASER INVISÍVEL AO ABRIR. EVITE EXPOSIÇÃO DIRECTA AO FEIXE.

GEVAAR - ONZICHTBARE LASERSTRALLEN BIJ GEOPENDE KLEP. DEZE KLEP NIET OPENEN.

ADVARSEL - USYNLIG LASERSTRÅLNING VED ÅBNING. NÅR SIKKERHEDSBRYDERE ER UDE AF FUNKTION. UNDGÅ UDSÆTTELSE FOR STRÅLNING.

ADVARSEL - USYNLIG LASERSTRÅLNING NÅR DEKSEL ÅPNES. STIHR IKKE INN I STRÅLEN. UNNGÅ EKSPONERING FOR STRÅLEN.

VARNING - OSYNLIG LASERSTRÅLNING NÅR DENNA DEL ÅR ÖPPEN OCH SPÄRREN ÅR URKÖPLAD. BETRakta EJ STRÅLEN. STRÅLEN ÅR FARLIG.

VARO! - AVATTAESSA JA SUOJALUKTUS CHITETTAESSA OLET ALTTIINA NÄKYMÄTTÖMÄLLE LASER-SÄTELYLLE ÄLÄ KATSO SÄTEESEEN.

注意 - 严禁揭开此盖, 以免激光泄露灼伤

주의 - 이 덮개를 열면 레이저광에 노출될 수 있으므로 주의하십시오.

JC48-10909A03

Class 1 Laser Statement label

The Class 1 laser label is located on the rear of the machine.

Example:

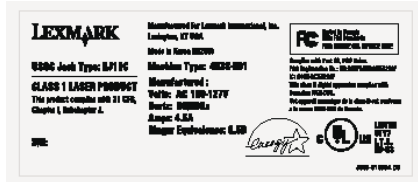

Laser notice

The printer is certified in the U.S. to conform to the requirements of DHHS 21 CFR Subchapter J for Class I (1) laser products, and elsewhere is certified as a Class I laser product conforming to the requirements of IEC 60825-1.

Class I laser products are not considered to be hazardous. The printer contains internally a Class IIIb (3b) laser that is nominally a 5 milliwatt gallium arsenide laser operating in the wavelength region of 770-795 nanometers. The laser system and printer are designed so there is never any human access to laser radiation above a Class I level during normal operation, user maintenance, or prescribed service condition.

Laser

Der Drucker erfüllt gemäß amtlicher Bestätigung der USA die Anforderungen der Bestimmung DHHS (Department of Health and Human Services) 21 CFR Teil J für Laserprodukte der Klasse I (1). In anderen Ländern gilt der Drucker als Laserprodukt der Klasse I, der die Anforderungen der IEC (International Electrotechnical Commission) 60825-1 gemäß amtlicher Bestätigung erfüllt.

Laserprodukte der Klasse I gelten als unschädlich. Im Inneren des Druckers befindet sich ein Laser der Klasse IIIb (3b), bei dem es sich um einen Galliumarsenlaser mit 5 Milliwatt handelt, der Wellen der Länge 770-795 Nanometer ausstrahlt. Das Lasersystem und der Drucker sind so konzipiert, daß im Normalbetrieb, bei der Wartung durch den Benutzer oder bei ordnungsgemäßer Wartung durch den Kundendienst Laserbestrahlung, die die Klasse I übersteigen würde, Menschen keinesfalls erreicht.

Avis relatif à l'utilisation de laser

Pour les Etats-Unis : cette imprimante est certifiée conforme aux provisions DHHS 21 CFR alinéa J concernant les produits laser de Classe I (1). Pour les autres pays : cette imprimante répond aux normes IEC 60825-1 relatives aux produits laser de Classe I.

Les produits laser de Classe I sont considérés comme des produits non dangereux. Cette imprimante est équipée d'un laser de Classe IIIb (3b) (arséniure de gallium d'une puissance nominale de 5 milliwatts) émettant sur des longueurs d'onde comprises entre 770 et 795 nanomètres. L'imprimante et son système laser sont conçus pour impossible, dans des conditions normales d'utilisation, d'entretien par l'utilisateur ou de révision, l'exposition à des rayonnements laser supérieurs à des rayonnements de Classe I .

Avvertenze sui prodotti laser

Questa stampante è certificata negli Stati Uniti per essere conforme ai requisiti del DHHS 21 CFR Sottocapitolo J per i prodotti laser di classe 1 ed è certificata negli altri Paesi come prodotto laser di classe 1 conforme ai requisiti della norma CEI 60825-1.

I prodotti laser di classe non sono considerati pericolosi. La stampante contiene al suo interno un laser di classe IIIb (3b) all'arseniuro di gallio della potenza di 5mW che opera sulla lunghezza d'onda compresa tra 770 e 795 nanometri. Il sistema laser e la stampante sono stati progettati in modo tale che le persone a contatto con la stampante, durante il normale funzionamento, le operazioni di servizio o quelle di assistenza tecnica, non ricevano radiazioni laser superiori al livello della classe 1.

Avisos sobre el láser

Se certifica que, en los EE.UU., esta impresora cumple los requisitos para los productos láser de Clase I (1) establecidos en el subcapítulo J de la norma CFR 21 del DHHS (Departamento de Sanidad y Servicios) y, en los demás países, reúne todas las condiciones expuestas en la norma IEC 60825-1 para productos láser de Clase I (1).

Los productos láser de Clase I no se consideran peligrosos. La impresora contiene en su interior un láser de Clase IIIb (3b) de arseniuro de galio de funcionamiento nominal a 5 milivatios en una longitud de onda de 770 a 795 nanómetros. El sistema láser y la impresora están diseñados de forma que ninguna persona pueda verse afectada por ningún tipo de radiación láser superior al nivel de la Clase I durante su uso normal, el mantenimiento realizado por el usuario o cualquier otra situación de servicio técnico.

Declaração sobre Laser

A impressora está certificada nos E.U.A. em conformidade com os requisitos da regulamentação DHHS 21 CFR Subcapítulo J para a Classe I (1) de produtos laser. Em outros locais, está certificada como um produto laser da Classe I, em conformidade com os requisitos da norma IEC 60825-1.

Os produtos laser da Classe I não são considerados perigosos. Internamente, a impressora contém um produto laser da Classe IIIb (3b), designado laser de arseneto de potássio, de 5 milliwatts ,operando numa faixa de comprimento de onda entre 770 e 795 nanómetros. O sistema e a impressora laser foram concebidos de forma a nunca existir qualquer possibilidade de acesso humano a radiação laser superior a um nível de Classe I durante a operação normal, a manutenção feita pelo utilizador ou condições de assistência prescritas.

Laserinformatie

De printer voldoet aan de eisen die gesteld worden aan een laserprodukt van klasse I. Voor de Verenigde Staten zijn deze eisen vastgelegd in DHHS 21 CFR Subchapter J, voor andere landen in IEC 60825-1.

Laserprodukten van klasse I worden niet als ongevaarlijk aangemerkt. De printer is voorzien van een laser van klasse IIIB (3b), dat wil zeggen een gallium arsenide-laser van 5 milliwatt met een golflengte van 770-795 nanometer. Het lasergeedeelte en de printer zijn zo ontworpen dat bij normaal gebruik, bij onderhoud of reparatie conform de voorschriften, nooit blootstelling mogelijk is aan laserstraling boven een niveau zoals voorgeschreven is voor klasse 1.

Lasermeddelelse

Printeren er godkendt som et Klasse I-laserprodukt, i overenstemmelse med kravene i IEC 60825-1.

Klasse I-laserprodukter betragtes ikke som farlige. Printeren indeholder internt en Klasse IIIB (3b)-laser, der nominelt er en 5 milliwatt galliumarsenid laser, som arbejder på bølglængdeområdet 770-795 nanometer. Lasersystemet og printeren er udformet således, at mennesker aldrig udsættes for en laserstråling over Klasse I-niveau ved normal drift, brugervedligeholdelse eller obligatoriske servicebetingelser.

Huomautus laserlaitteesta

Tämä kirjoitin on Yhdysvalloissa luokan I (1) laserlaitteiden DHHS 21 CFR Subchapter J -määrityksen mukainen ja muualla luokan I laserlaitteiden IEC 60825-1 -määrityksen mukainen.

Luokan I laserlaitteiden ei katsota olevan vaarallisia käyttäjälle. Kirjoittimessa on sisäinen luokan IIIb (3b) 5 milliwatin galliumarsenidilaser, joka toimii aaltoalueella 770 - 795 nanometriä. Laserjärjestelmä ja kirjoitin on suunniteltu siten, että käyttäjä ei altistu luokan I määräyksiä voimakkaammalle säteilylle kirjoittimen normaalin toiminnan, käyttäjän tekemien huoltotoimien tai muiden huoltotoimien yhteydessä.

VARO! Avattaessa ja suojalukitus ohitettaessa olet alttiina näkymättömälle lasersäteilylle. Älä katso säteeseen.

WARNING! Osynlig laserstrålning när denna del är öppnad och spärren är urkopplad. Betrakta ej strålen.

Laser-notis

Denna skrivare är i USA certifierad att motsvara kraven i DHHS 21 CFR, underparagraf J för laserprodukter av Klass I (1). I andra länder uppfyller skrivaren kraven för laserprodukter av Klass I enligt kraven i IEC 60825-1.

Laserprodukter i Klass I anses ej hälsovådliga. Skrivaren har en inbyggd laser av Klass IIIb (3b) som består av en laserenhet av gallium-arsenid på 5 milliwatt som arbetar i våglängdsområdet 770-795 nanometer. Lasersystemet och skrivaren är utformade så att det aldrig finns risk för att någon person utsätts för laserstrålning över Klass I-nivå vid normal användning, underhåll som utförs av användaren eller annan föreskriven serviceåtgärd.

Laser-melding

Skriveren er godkjent i USA etter kravene i DHHS 21 CFR, underkapittel J, for klasse I (1) laserprodukter, og er i andre land godkjent som et Klasse I-laserprodukt i samsvar med kravene i IEC 60825-1.

Klasse I-laserprodukter er ikke å betrakte som farlige. Skriveren inneholder internt en klasse IIIb (3b)-laser, som består av en gallium-arsenlaserenhet som avgir stråling i bølgelengdeområdet 770-795 nanometer. Lasersystemet og skriveren er utformet slik at personer aldri utsettes for laserstråling ut over klasse I-nivå under vanlig bruk, vedlikehold som utføres av brukeren, eller foreskrevne serviceoperasjoner.

Avís sobre el Làser

Segons ha estat certificat als Estats Units, aquesta impressora compleix els requisits de DHHS 21 CFR, apartat J, pels productes làser de classe I (1), i segons ha estat certificat en altres llocs, és un producte làser de classe I que compleix els requisits d'IEC 60825-1.

Els productes làser de classe I no es consideren perillosos. Aquesta impressora conté un làser de classe IIIb (3b) d'arseniür de gal.li, nominalment de 5 mil.liwats, i funciona a la regió de longitud d'ona de 770-795 nanòmetres. El sistema làser i la impressora han sigut concebuts de manera que mai hi hagi exposició a la radiació làser per sobre d'un nivell de classe I durant una operació normal, durant les tasques de manteniment d'usuari ni durant els serveis que satisfacin les condicions prescrites.

Japanese Laser Notice

レーザーに関するお知らせ

このプリンターは、米国ではDHHS 21 CFRサブチャプターJのクラスI(1)の基準を満たしたレーザー製品であることが証明されています。また米国以外ではIEC 825の基準を満たしたクラスIのレーザー製品であることが証明されています。

クラスIのレーザー製品には危険性はないと考えられています。このプリンターはクラスIII b(3b)のレーザーを内蔵しています。このレーザーは、波長が770 ~ 795ナノメートルの範囲で、通常5ミリワットのガリウム砒化物を放射するレーザーです。このレーザーシステムとプリンターは、通常の操作、ユーザのメンテナンス、規定された修理においては、人体がクラスIのレベル以上のレーザー放射に晒されることのないよう設計されています。

Chinese Laser Notice

注意：

本打印机被美国认证合乎 DHHS 21 CFR Subchapter I 对分类 I (1) 激光产品的标准，而在其他地区则被认证合乎 IEC 825 的标准。

分类 I 激光产品一般认为不具危险性，本打印机内部含有分类 IIIb (3b) 的激光，在操作过程中会产生 5 毫瓦含镓及砷的微量激光，其波长范围在 770-795 nm 之间。本激光系统及打印机的设计，在一般操作、使用者维护或规定内的维修情况下，不会使人体接触分类 I 以上等级的辐射。

Korean Laser Notice

본프린터는 1등급 레이저 제품들에 대한 DHHS 21 CFR Subchapter 3의 규정을 준수하고 있음을 미국에서 인증받았으며, 그외의 나라에서도 IEC 825 규정을 준수하는 1등급 레이저 제품으로서 인증을 받았습니다.

1등급 레이저 제품들은 안전한 것으로 간주됩니다. 본 프린터는 5 밀리와트 갈륨 아르세나이드 레이저로서 770-795 나노미터의 파장대에서 활동하는 Class III (3b) 레이저를 내부에 갖고 있습니다. 본 레이저 시스템과 프린터는 정상 작동 중이나 유지 보수 중 또는 규정된 서비스 상태에서 상기의 Class I 수준의 레이저 방출에 사람이 절대 접근할 수 없도록 설계되어 있습니다.

Safety information

- The safety of this product is based on testing and approvals of the original design and specific components. The manufacturer is not responsible for safety in the event of use of unauthorized replacement parts.
- The maintenance information for this product has been prepared for use by a professional service person and is not intended to be used by others.
- There may be an increased risk of electric shock and personal injury during disassembly and servicing of this product. Professional service personnel should understand this and take necessary precautions.
-  **CAUTION:** When you see this symbol, there is a danger from hazardous voltage in the area of the product where you are working. Unplug the product before you begin, or use caution if the product must receive power in order to perform the task.

Consignes de sécurité

- La sécurité de ce produit repose sur des tests et des agréments portant sur sa conception d'origine et sur des composants particuliers. Le fabricant n'assume aucune responsabilité concernant la sécurité en cas d'utilisation de pièces de rechange non agréées.
- Les consignes d'entretien et de réparation de ce produit s'adressent uniquement à un personnel de maintenance qualifié.
- Le démontage et l'entretien de ce produit pouvant présenter certains risques électriques, le personnel d'entretien qualifié devra prendre toutes les précautions nécessaires.
-  **ATTENTION :** Ce symbole indique la présence d'une tension dangereuse dans la partie du produit sur laquelle vous travaillez. Débranchez le produit avant de commencer ou faites preuve de vigilance si l'exécution de la tâche exige que le produit reste sous tension.

Norme di sicurezza

- La sicurezza del prodotto si basa sui test e sull'approvazione del progetto originale e dei componenti specifici. Il produttore non è responsabile per la sicurezza in caso di sostituzione non autorizzata delle parti.
- Le informazioni riguardanti la manutenzione di questo prodotto sono indirizzate soltanto al personale di assistenza autorizzato.
- Durante lo smontaggio e la manutenzione di questo prodotto, il rischio di subire scosse elettriche e danni alla persona è più elevato. Il personale di assistenza autorizzato deve, quindi, adottare le precauzioni necessarie.
-  **ATTENZIONE:** Questo simbolo indica la presenza di tensione pericolosa nell'area del prodotto. Scollegare il prodotto prima di iniziare o usare cautela se il prodotto deve essere alimentato per eseguire l'intervento.

Sicherheitshinweise

- Die Sicherheit dieses Produkts basiert auf Tests und Zulassungen des ursprünglichen Modells und bestimmter Bauteile. Bei Verwendung nicht genehmigter Ersatzteile wird vom Hersteller keine Verantwortung oder Haftung für die Sicherheit übernommen.
- Die Wartungsinformationen für dieses Produkt sind ausschließlich für die Verwendung durch einen Wartungsfachmann bestimmt.
- Während des Auseinandernehmens und der Wartung des Geräts besteht ein zusätzliches Risiko eines elektrischen Schlags und körperlicher Verletzung. Das zuständige Fachpersonal sollte entsprechende Vorsichtsmaßnahmen treffen.
-  **ACHTUNG:** Dieses Symbol weist auf eine gefährliche elektrische Spannung hin, die in diesem Bereich des Produkts auftreten kann. Ziehen Sie vor den Arbeiten am Gerät den Netzstecker des Geräts, bzw. arbeiten Sie mit großer Vorsicht, wenn das Produkt für die Ausführung der Arbeiten an den Strom angeschlossen sein muß.

Pautas de Seguridad

- La seguridad de este producto se basa en pruebas y aprobaciones del diseño original y componentes específicos. El fabricante no es responsable de la seguridad en caso de uso de piezas de repuesto no autorizadas.
- La información sobre el mantenimiento de este producto está dirigida exclusivamente al personal cualificado de mantenimiento.
- Existe mayor riesgo de descarga eléctrica y de daños personales durante el desmontaje y la reparación de la máquina. El personal cualificado debe ser consciente de este peligro y tomar las precauciones necesarias.
-  **PRECAUCIÓN:** este símbolo indica que el voltaje de la parte del equipo con la que está trabajando es peligroso. Antes de empezar, desenchufe el equipo o tenga cuidado si, para trabajar con él, debe conectarlo.

Informações de Segurança

- A segurança deste produto baseia-se em testes e aprovações do modelo original e de componentes específicos. O fabricante não é responsável pela segurança, no caso de uso de peças de substituição não autorizadas.
- As informações de segurança relativas a este produto destinam-se a profissionais destes serviços e não devem ser utilizadas por outras pessoas.
- Risco de choques eléctricos e ferimentos graves durante a desmontagem e manutenção deste produto. Os profissionais destes serviços devem estar avisados deste facto e tomar os cuidados necessários.
-  **CUIDADO:** Quando vir este símbolo, existe a possível presença de uma potencial tensão perigosa na zona do produto em que está a trabalhar. Antes de começar, desligue o produto da tomada eléctrica ou seja cuidadoso caso o produto tenha de estar ligado à corrente eléctrica para realizar a tarefa necessária.

Informació de Seguretat

- La seguretat d'aquest producte es basa en l'avaluació i aprovació del disseny original i els components específics. El fabricant no es fa responsable de les qüestions de seguretat si s'utilitzen peces de recanvi no autoritzades.
- La informació pel manteniment d'aquest producte està orientada exclusivament a professionals i no està destinada a ningú que no ho sigui.
- El risc de xoc elèctric i de danys personals pot augmentar durant el procés de desmuntatge i de servei d'aquest producte. El personal professional ha d'estar-ne assabentat i prendre les mesures convenients.
-  **PRECAUCIÓ:** aquest símbol indica que el voltatge de la part de l'equip amb la qual esteu treballant és perillós. Abans de començar, desendolleu l'equip o extremeu les precaucions si, per treballar amb l'equip, l'heu de connectar.

안전 사항

- 본 제품은 원래 설계 및 특정 구성품에 대한 테스트 결과로 안정성이 입증된 것입니다. 따라서 무허가 교체부품을 사용하는 경우에는 제조업체에서 안전에 대한 책임을 지지 않습니다.
- 본 제품에 관한 유지 보수 설명서는 전문 서비스 기술자용으로 작성된 것이므로, 비전문가는 사용할 수 없습니다.
- 본 제품을 해체하거나 정비할 경우, 전기적인 충격을 받거나 상처를 입을 위험이 큽니다. 전문 서비스 기술자는 이 사실을 숙지하고, 필요한 예방 조치를 취하도록 하십시오.
-  **주의:** 이 표시는 해당영역에서 고압전류가 흐른다는 위험 표시입니다. 시작전에 플러그를 뽑으시거나, 주의를 기울여 주시기 바랍니다.

安全信息

本产品的安全性以原来设计和特定产品的测试结果和认证为基础。万一使用未经许可的替换部件，制造商不对安全性负责。

本产品的维护信息仅供专业服务人员使用，并不打算让其他人使用。

本产品在拆卸、维修时，遭受电击或人员受伤的危险性会增高，专业服务人员对这点必须有所了解，并采取必要的预防措施。



切记：当您看到此符号时，说明在您工作的产品区域有危险电压的存在。请在开始操作前拔掉产品的电源线，或者在产品必须使用电源来执行任务时，小心从事。

Preface

This manual contains maintenance procedures for service personnel. It is divided into the following chapters:

1. **General information** contains a general description of the printer and the maintenance approach used to repair it. Special tools and test equipment are listed, as well as general environmental and safety instructions.
2. **Diagnostic information** contains an error indicator table, symptom tables, and service checks used to isolate failing field replaceable units (FRUs).
3. **Diagnostic aids** contains tests and checks used to locate or repeat symptoms of printer problems.
4. **Repair information** provides instructions for making printer adjustments and removing and installing FRUs.
5. **Connector locations** uses illustrations to identify the connector locations and test points on the printer.
6. **Preventive maintenance** contains the lubrication specifications and recommendations to prevent problems.
7. **Parts catalog** contains illustrations and part numbers for individual FRUs.

Definitions

Note: A note provides additional information.

Warning: A warning identifies something that might damage the product hardware or software.

CAUTION: A caution identifies something that might cause a servicer harm.



CAUTION: When you see this symbol, there is a danger from hazardous voltage in the area of the product where you are working. Unplug the product before you begin, or use caution if the product must receive power in order to perform the task.

1. General information

The Lexmark™ X215 MFP is a compact multifunction printer that offers scanning, printing, copying, and faxing.



Machine features

Print speeds	up to 17 ppm
Print resolution	up to 600 x 600 dpi
Paper tray capacity	up to 250–sheets
Front output bin	150–sheet capacity
Manual bypass paper feeder	one page at a time
Automatic document feeder (ADF)	30–sheet capacity
Compatible with various operating systems	Windows 98, Windows NT 4.0, Windows 2000, and Windows XP

Print materials

Always use print materials that meet the guidelines for use with this machine. Using print materials not recommended may cause paper jams or print quality problems.

Selecting print materials

Size (mm/in.)	Input source/capacity ¹	
	Paper tray	Bypass feeder
Plain paper Letter (215.9 x 279/8.5 x 11) A4 (210 x 297/8.27 x 11.69) Folio (215.9 x 330.2/8.5 x 13) Legal (215.9 x 355.6/8.5 x 14) Executive (184.2 x 266.7/7.25 x 10.5) B5 (182 x 257/7.2 x 10)	Yes/250	Yes/1
A5 (148 x 210/5.83 x 8.27) A6 (105 x 148/4.13 x 5.88)	No/0	Yes/1
Envelopes No.9 (98.4 x 225.4/3.88 x 8.88) No.10 (104.8 x 241.3/4.12 x 9.5) DL (110 x 220/4.33 x 8.66) C5 (162 x 229/6.38 x 9.02) C6 (114 x 162/4.49 x 6.38) B5 (176 x 250/6.93 x 9.84) No.7 3/4 (98.4 x 190.4/3.88 x 5.83)	No/0	Yes/1
Labels² Letter (215.9 x 279/8.5 x 11) A4 (210 x 297/8.27 x 11.69)	No/0	Yes/1
Transparency films² Letter (215.9 x 279/8.5 x 11) A4 (210 x 297/8.27 x 11.69)	No/0	Yes/1

Size (mm/in.)	Input source/capacity ¹	
	Paper tray	Bypass feeder
Card stocks² A6 card (105 x 148/4.13 x 5.88) Post Card (101.6 x 152.4/4 x 6) Hagaki (100 x 148/3.94 x 5.83)	No/0	Yes/1
¹ Maximum capacity may be reduced depending on paper thickness. ² Media must be fed one sheet at a time through manual bypass.		

Paper and speciality media guidelines

When selecting or loading paper, envelopes, transparencies, or other specialty media, keep these guidelines in mind:

- Attempting to print on damp, curled, wrinkled, or torn paper can cause paper jams and poor print quality.
- Use only high quality, copier grade paper. Avoid paper with embossed lettering, perforations, or texture that is too smooth or too rough.
- Store paper in its ream wrapper until ready to use. Place cartons on pallets or shelves, not on the floor. Do not place heavy objects on top of the paper, whether it is packaged or loose. Keep it away from moisture, or other conditions that could cause it to wrinkle or curl.
- During storage, you should use moisture-proof wrap, such as a plastic container or bag, to prevent dust and moisture from contaminating your paper.
- Always use paper and other materials that conform with those listed in **“Selecting print materials” on page 1-2.**
- Use only well-constructed envelopes with sharp, well creased folds.
- Do *not* use envelopes with clasps and snaps.
- Do *not* use envelopes with windows, coated lining, self-adhesive seals, or other synthetic materials.
- Do *not* use damaged or poorly made envelopes.

4038-001

- Load specialty media one sheet at a time.
- Use only materials recommended for use with laser printers.
- To prevent specialty media, such as transparencies and label sheets, from sticking together, remove each sheet from the output tray as it is printed.
- Place transparencies on a flat surface after removing them from the machine.
- Do not leave transparencies in the paper tray for long periods of time. Dust and dirt may accumulate on the film, resulting in spotty printing.
- To avoid smudging caused by fingerprints, handle transparencies and coated paper carefully.
- To avoid fading, do not expose the printed transparencies to prolonged sunlight.
- Store unused materials at temperatures between 59° F and 86° F (15° C to 30° C). The relative humidity should be between 10% and 70%.
- The laser printing process heats paper to high temperatures of 180° C (356° F). Use only paper able to withstand these temperatures without discoloring, bleeding, or releasing hazardous emissions. Check with the manufacturer or vendor to determine whether the paper chosen is acceptable for laser printers.
- Verify that label adhesive materials can tolerate a fusing temperature of 180° C (356° F) for 0.1 second.
- Make sure there is no exposed adhesive material between labels. Exposed areas can cause labels to peel off during printing, which can cause paper jams. Exposed adhesive can also damage machine components.
- Do not load a sheet of labels through the machine more than once. The adhesive backing is designed for only one pass through the machine.

Note: Do not use labels that are separating from the backing sheet or are wrinkled, bubbled, or damaged.

Cleaning the machine

To maintain print quality, follow these cleaning procedures each time the toner cartridge is replaced or if print quality problems occur.

- Do not put water directly onto any part of the machine.
- Do not use ammonia-based cleaners or volatile solvents, such as thinner, on the printer.
- While cleaning the inside of the machine, be careful not to touch the transfer roller located under the toner cartridge. Oil from your fingers can affect print quality.

Cleaning the outside of the machine

Wipe the outside surface of the machine with a soft, clean, lint-free cloth. If you dampen the cloth slightly with water, be careful not to let any water drip onto or inside the machine.

Cleaning the inside of the machine

During the printing process, paper, toner, and dust particles can accumulate inside the machine. This buildup can cause print quality problems, such as toner specks or smearing.

1. Turn the machine off, unplug the power cord, and then wait for the machine to cool down.
2. Open the front cover and remove the toner cartridge.

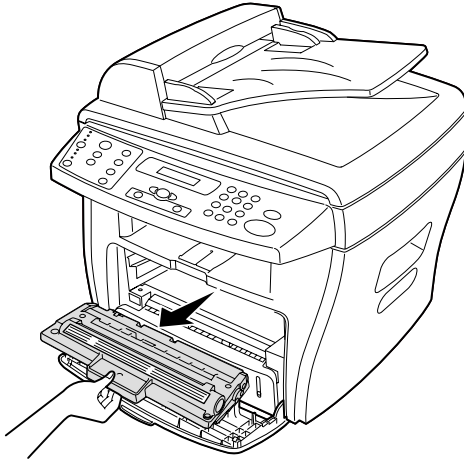

CAUTION: Do *not* touch the photoconductor drum located on the bottom of the toner cartridge.

3. Place the toner cartridge on a clean, dry surface.

4. With a dry, lint-free cloth, wipe away any dust and spilled toner from the toner cartridge area and the toner cartridge cavity.

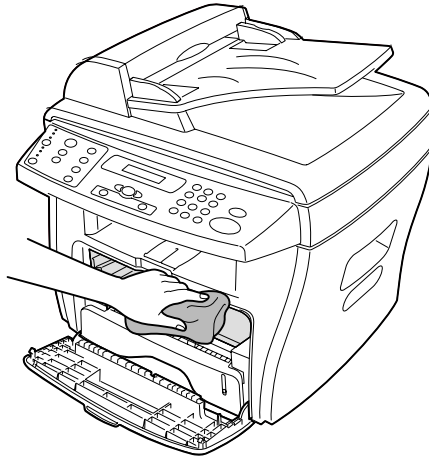
**Warning:**

- To prevent damage to the toner cartridge, do not expose it to light for more than a few minutes. Cover it with a piece of paper, if necessary.
 - Do not touch the black transfer roller.
5. Reinsert the toner cartridge and close the cover.
 6. Plug in the power cord and turn the machine on.

Cleaning the scan unit

Keeping the scan unit clean helps ensure the best possible copies.

1. Slightly dampen a soft, lint-free cloth or paper towel with water.
2. Open the document cover.
3. Wipe the surfaces of the document glass and ADF until they are clean and dry.

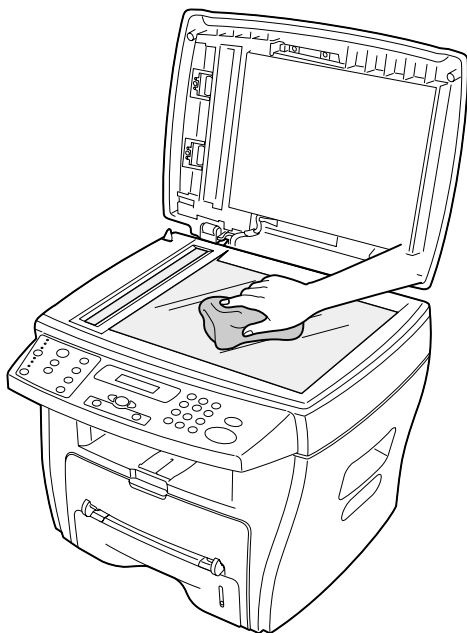

4. Wipe the underside of the white document cover and white sheet until it is clean and dry.
5. Close the document cover.

Cleaning the photoconductor drum

If there are streaks or spots on your print, the photoconductor drum may require cleaning. The operator panel menu includes a Clean Drum option that may help to improve the print quality.

To clean the photoconductor drum:

1. Make sure paper is loaded.
2. Press **Menu** until MACHINE SETUP appears on the top line of the display, and then press **Select**.
3. Press the scroll button ◀ or ▶ until CLEAN DRUM appears on the bottom line of the display, and then press **Select**.

The machine prints out a cleaning page. Toner particles on the photoconductor surface are affixed to the paper.

If the problem persists, repeat these steps.

If the photoconductor drum has been cleaned several times and the problem is still unresolved, install a new toner cartridge.

Maintenance approach

The diagnostic information in this manual leads you to the correct field replaceable unit (FRU) or part. Use the error messages, and diagnostic aids to determine the printer problem and repair the failure. After you complete the repair, perform tests as needed to verify the repair.

Tools

The removal and adjustment procedures require the following tools and equipment:

- Analog or digital multimeter
- Pliers: diagonal and needle-nose
- Screwdrivers: #1 and #2 Phillips
- Cotton swab

When you make voltage readings, always use frame ground unless another ground is specified.

Abbreviations

ADF	Automatic document feed
BPS	Bits per second
CCD	Charge-coupled device
CCITT	International consultative committee on telephone and telegraphy
dB	Decibel
DPI	Dots per inch
DRAM	Dynamic random access memory
EP	Electrophotographic process
ESD	Electrostatic discharge
FRU	Field replaceable unit
HSYNC	
HVPS	High voltage power supply
Kbps	Kilobits per second
LCD	Liquid crystal display
LED	Light-emitting diode
LSU	Laser scan unit
LVPS	Low voltage power supply
OPC	Optical photoconductor drum
PC	Photoconductor
PTL	Pre-transfer LED
RH	Relative humidity
ROM	Read only memory
USB	Universal serial bus
V ac	Volts alternating current
V dc	Volts direct current

2. Diagnostic information

Start

CAUTION: NEVER manually actuate or disable the top cover interlock switch and the printhead shutter actuator at the same time. To perform some of the service checks and tests, such as troubleshooting paper feed problems, you need to actuate the top cover interlock switch with the covers opened or removed and power applied to the machine. It is important for personal safety that you **DO NOT, FOR ANY REASON**, disable the printhead shutter actuator when power is on.



Remove power from the printer before you connect or disconnect any cable or electronic board or assembly for personal safety and to prevent damage to the printer.

Use the error message table, and symptom table in this chapter to determine the corrective action necessary to repair a malfunctioning printer.

The LCD on the operator panel can indicate an error message. See the **“Error message table” on page 2-2** to determine the meaning of the message and what corrective action to take.

If the printer does not have an error message, go to the **“Symptom table” on page 2-10**. Locate the symptom and take appropriate action to correct the problem.



Error message table

Clearing display messages:

Display	Meaning	Solution
Bypass Jam	Paper was sensed at the manual bypass sensor, but not at the main paper feed/toner cartridge present sensor.	<ul style="list-style-type: none"> • Load paper in the manual bypass or remove the jam from the manual bypass. • Make sure the main paper feed/toner cartridge present sensor actuator is not broken, improperly installed or stuck with paper debris. • Perform the “Sensor test” on page 3-16 to check proper operation of the sensor. • If the sensor works properly, the problem is likely associated with the system board. • If the paper path and sensor actuator are clear and working properly, and the problem persists, replace the HVPS/LVPS. <p>Note: This sensor is a component of the HVPS/LVPS.</p>

Display	Meaning	Solution
Document Jam	Paper was sensed at the ADF registration sensor, but not at the ADF scan sensor.	<ul style="list-style-type: none"> • Make sure the ADF scan sensor actuator is not broken, improperly installed or stuck with paper debris. • If the paper path and sensor actuator are clear and working properly, replace the scanner assembly.
Door Open	Front or rear cover is not securely latched.	<ul style="list-style-type: none"> • Close the front toner cartridge access cover until it locks. • If the message does not clear, perform the “Sensor test” on page 3-16 to check proper operation of the switch. • If the switch works properly, the problem is likely associated with the system board. • If the switch does not work in the test, make sure the cover open actuator is working properly. When the cover closes, the cover should push the actuator, causing the cover open switch on the HVPS/LVPS to close. <p>Note: This process is viewable with the right cover removed.</p> <ul style="list-style-type: none"> • If all moving parts appear to be working correctly, and the messages does not clear, replace the HVPS/LVPS.

Display	Meaning	Solution
 Fuser Error	Problem in the fuser unit.	<ul style="list-style-type: none"> • Make sure CN1 and CN7 on the HVPS/LVPS are properly connected. • Check CN1 on the HVPS/LVPS for proper voltage. • If the voltage is correct, replace the fuser. • Otherwise, replace the HVPS/LVPS.
Load Bypass	No document loaded in the manual bypass.	Load print media into the manual bypass and try again.
LSU Error	A problem in the LSU (laser scanning unit).	<ul style="list-style-type: none"> • Make sure all cables are properly connected to the printhead. • If correct, replace the printhead.
Memory Full	Collated copy is too large for memory.	Reduce the number of pages in the job.
No Cartridge	Toner cartridge not installed.	Install the toner cartridge.
No Paper	No paper in the paper tray.	<ul style="list-style-type: none"> • If paper exists in the paper tray but this message is displayed, make sure the paper empty sensor actuator is not broken or improperly installed. • If the actuator is working properly, replace the HVPS/LVPS.

Display	Meaning	Solution
 Open Heat Error	The printer senses that the thermistor isn't connected or faulty.	<ul style="list-style-type: none">• Make sure the thermistor is properly connected to CN7 on the HVPS/LVPS.• If the problem persists replace the fuser.
 Overheat	The fuser unit has overheated.	Replace the fuser.

Display	Meaning	Solution
Paper Jam 0	Paper was sensed at the paper tray empty sensor, but not at the manual bypass.	<ul style="list-style-type: none"> • Go to the paper path diagram “Printer engine paper path/ paper jams” on page 5-15 to see the region where a paper jam may occur. • Remove any obstructions and other paper debris. • Make sure the manual bypass sensor actuator is not broken, improperly installed or stuck with paper debris. • Perform the “Sensor test” on page 3-16 to check proper operation of the sensor. • If the sensor works properly, the problem is likely associated with the system board. • If the paper path and sensor actuator are clear and working properly, and the problem persists, replace the HVPS/ LVPS. <p>Note: This sensor is a component of the HVPS/LVPS.</p>

Display	Meaning	Solution
Paper Jam 1	The fuser exit sensor sensed the leading edge of the page but never sensed the trailing edge.	<ul style="list-style-type: none"> • Go to the paper path diagram “Printer engine paper path/ paper jams” on page 5-15 to see the region where a paper jam may occur. • Remove any obstructions and other paper debris. • Perform the “Sensor test” on page 3-16 to check proper operation of the sensor. • If the sensor works properly, the problem is likely associated with the system board. • Make sure the fuser exit sensor isn’t stuck with debris or improperly installed. • If the paper path and sensor actuator are clear and working properly, replace the HVPS/LVPS. <p>Note: This sensor is a component of the HVPS/LVPS.</p>

Display	Meaning	Solution
Paper Jam 2	Paper was sensed at the main paper feed/ toner cartridge present sensor, but not at the fuser exit sensor.	<ul style="list-style-type: none"> • Go to the paper path diagram “Printer engine paper path/ paper jams” on page 5-15 to see the region where a paper jam may occur. • Remove any obstructions and other paper debris. • Perform the “Sensor test” on page 3-16 to check proper operation of the sensor. • If the sensor works properly, the problem is likely associated with the system board. • Make sure the fuser exit sensor actuator is not broken, improperly installed or stuck with paper debris. • If the paper path and sensor actuator are clear and working properly, and the problem persists, replace the HVPS/ LVPS. <p>Note: This sensor is a component of the HVPS/LVPS.</p>
Power Failure	Power interruption and the machine’s memory is not saved.	Restart the print job.

Display	Meaning	Solution
Time/Date prompt	Prompt appears when the machine is powered on.	<ul style="list-style-type: none"> • Use the numeric keypad to enter the two-digit month and day, and the four-digit year. For example, 01-23-2003. • Enter the current time. The default clock setting is 12-hour. • Press the asterisk (*) to select AM or PM, and then press Select. <p>Note: If the machine is unplugged for longer than 15 minutes, or turned off for longer than an hour, when the power is turned back on, the machine prompts you to reset the correct date and time.</p>
Toner Empty	Toner cartridge has run out.	Install a new toner cartridge.
Toner Low	Toner is nearly empty.	Remove the toner cartridge and gently shake it. This temporarily reestablishes printing.

Symptom table

Symptom	Reference
Paper feed problems	See “Paper feed problems” on page 2-11.
Printing and copying problems	See “Printing and copying problems” on page 2-13.
Scanning problems	See “Scanning problems” on page 2-18.
Faxing problems	See “Faxing problems” on page 2-19.
Print quality problems	See “Print quality checks” on page 2-21.
Dead machine (no power)	See “Dead machine” on page 2-32.
Fan noisy or not working	See “Cooling fan” on page 2-30.
Main motor noisy or does not move	See “Main drive motor” on page 2-31.

Paper feed problems

Symptom	Possible cause and solution
Paper jam	Clear the paper jam.
Paper sticks together	<ul style="list-style-type: none"> • Ensure that there is not too much paper in the paper tray. Depending on the thickness of your paper, the paper tray can hold up to 250–sheets of paper. • Make sure the correct type of paper is used. See “Selecting print materials” on page 1-2 for more information. • Remove paper from the paper tray and flex or fan the paper. • Humid conditions may cause some paper to stick together.
Multiple sheets do not feed	<ul style="list-style-type: none"> • Different types of paper may be stacked in the paper tray. Load paper of only one type, size, and weight. • When loading paper, do not force the paper down into the machine. • If multiple sheets have caused a paper jam, clear the paper jam.
Paper skews or buckles	<ul style="list-style-type: none"> • Ensure there is not too much paper in the paper tray. Depending on the thickness of your paper, the paper tray can hold up to 250–sheets. • Make sure the paper guide lightly touches the paper and does not cause the paper to bow in the paper tray. • Make sure you are using the correct type of paper. See “Selecting print materials” on page 1-2 for more information.

Symptom	Possible cause and solution
Paper does not feed.	<ul style="list-style-type: none"> • Paper is not loaded correctly. Remove paper from the tray and reload it correctly. • There is too much paper loaded. Remove excess paper from the tray. • The paper is too thick. Use only paper that meets specifications. • Remove any obstructions. • If the problem persists in the ADF, replace the ADF pick roller/separator pad assembly. • If the problem persists in the paper tray, replace the paper tray pick roller assembly.
Paper keeps jamming.	<ul style="list-style-type: none"> • There is too much paper loaded. Remove excess paper from the tray. If printing on special materials, use the manual bypass. • An incorrect type of paper is being used. Use only paper that meets specifications. See “Selecting print materials” on page 1-2 for more information. • There may be debris inside the machine. Open the front cover and remove the debris. • If the problem persists in the ADF, replace the ADF pick roller/separator pad assembly. • If the problem persists in the paper tray, replace the paper tray pick roller assembly.
Transparencies stick together in the paper exit.	Use only transparencies specially designed for a laser printer. Remove each transparency as it exits the machine.
Envelopes skew or fail to feed correctly.	Ensure that the manual bypass guides are against both sides of the envelopes.

Printing and copying problems

Problem	Possible cause	Solution
 Machine does not print	Machine is not receiving power.	<ul style="list-style-type: none"> • Check the power cord connections. • Check the power switch and the power source.
	Machine is busy scanning.	Wait until scanning is complete before using the printer.
	Machine is not selected as the default printer.	Select Lexmark X215 as your default printer in Windows.
	Front or rear covers are not closed.	Close the covers.
	Paper jam.	Clear the paper jam.
	No paper loaded.	Load paper.
	Toner cartridge is not installed.	Install the toner cartridge.
	Connection cable between the computer and the machine is not connected properly.	Disconnect the printer cable, and then reconnect it.
	Connection cable between the computer and the machine is defective.	<ul style="list-style-type: none"> • If possible, attach the cable to another computer that is working properly and print a job. • Try a new printer cable.
Port setting is incorrect.	<ul style="list-style-type: none"> • Check the Windows printer setting to make sure that the print job is sent to the correct port, for example, LPT1. • If the computer has more than one port, make sure that the machine is attached to the correct one. 	

Problem	Possible cause	Solution
	Configuration incorrect.	Ensure the printer settings are correct.
	Machine is malfunctioning.	Check the message on the operator panel to determine if the machine is indicating a system error.
Print job is extremely slow	Job may be very complex.	<ul style="list-style-type: none"> • Reduce the complexity of the page. • Adjust the print quality settings.
	If using Windows 98/Me, the spool setting may be set incorrectly.	<ol style="list-style-type: none"> 1. Click Start ▶ Settings ▶ Printers. 2. Right-click the Lexmark X215 printer icon. 3. Click Properties. 4. From the Details tab, click Spool Settings. 5. Select the spool setting you want.
Half the page is blank	Page orientation setting may be incorrect.	Change the page orientation in your program.
	Paper size and the paper size settings do not match.	Ensure that the paper size in the printer driver settings matches the paper in the tray.
Machine prints, but the text is wrong, garbled, or incomplete	Printer cable is loose or defective.	<ul style="list-style-type: none"> • Disconnect the printer cable, and then reconnect it. • Try a print job that you have already printed successfully. • If possible, attach the cable and the machine to another computer and try another print job. • Try a new printer cable.
	Wrong printer driver selected.	Check the program's printer selection menu to ensure that your machine is selected.

Problem	Possible cause	Solution
	Software program is malfunctioning.	Try printing a job from another program.
	Operating system is malfunctioning.	<ul style="list-style-type: none"> • Exit Windows and restart the computer. • Turn the machine off and then back on again.
Illustrations print incorrectly in Adobe Illustrator	The setting in the software program is wrong.	Print the document with Download as Bit Image selected in the Advanced Options window of the graphic properties.
Error occurs repeatedly when printing with the USB connection	When the USB mode is set to FAST, some users may experience poor USB communication.	<p>Change the USB mode to SLOW.</p> <ol style="list-style-type: none"> 1. Press Menu. 2. Press the scroll button (◀ OR ▶) until MACHINE SETUP appears on the top line of the display, and then press Select. 3. Press the scroll button until USB appears on the bottom line of the display, and press Select. 4. Press the scroll button until SLOW appears on the bottom line of the display, and press Select. 5. To return to the Ready prompt, press Stop/Clear.
LCD does not turn on	Machine is not receiving power.	<ul style="list-style-type: none"> • Check that the machine is plugged into a properly grounded electrical outlet. • Ensure that there is power to the outlet and that the machine power switch is in the On position. • Go to “Dead machine” on page 2-32 for more information.

Problem	Possible cause	Solution
Copies are too light or too dark		<ul style="list-style-type: none"> • If the original is light, press Darkness to darken the background of the copies. • If the original is dark, press Darkness to lighten the background of the copies.
Smears, lines, marks, or spots on copies	Document glass or document cover is dirty.	<ul style="list-style-type: none"> • If defects appear on the original, press Darkness to lighten the background of your copies. • If no defects appear on the original, clean the document glass and underside of the document cover.
Copy image is skewed	Original document not positioned correctly.	<ul style="list-style-type: none"> • Ensure the original is positioned correctly on document glass or that ADF paper guides are aligned. • Check that paper is loaded correctly.
Blank copies	Original document not positioned correctly.	Ensure that the original is facedown on the document glass or faceup in the ADF.
Image rubs off the copy easily.		<ul style="list-style-type: none"> • Ensure the correct media type is selected. • Replace paper with a fresh supply. • In high humidity areas, do not leave paper in the machine for extended periods of time.

Problem	Possible cause	Solution
Frequent jams		<ul style="list-style-type: none"> • Check/adjust paper guides. • Fan the stack of paper, and then turn it over in the paper tray. • Replace paper with a fresh supply. • Ensure the paper is the proper paper weight. 20 lb. (75 g/m²) bond paper is recommended. • Check for paper or pieces of paper remaining in the machine after a jam is cleared.
Fewer copies from the toner cartridge than expected.	<ul style="list-style-type: none"> • Originals contain pictures, solids, or heavy lines. • Originals are forms, newsletters, books, and so on. • The machine is turned on and off frequently. • The document cover is left open while copies are made. 	Ensure document cover is closed when making copies.

Scanning problems

Problem	Possible cause and solution
Scanner does not work.	<ul style="list-style-type: none"> • Machine may be busy printing. Wait until printing completes before using the scanner. • Make sure the document to be scanned is facedown on the document glass, or faceup in the Automatic Document Feeder. • Check that the USB or parallel cable is connected properly. • Check that the USB or parallel cable is not defective. Swap the cable with a known good cable. If necessary, replace the cable. • If using a parallel cable, ensure that it is compliant with the IEEE-1284 standard. • Make sure that the scanner job is sent to the correct port (for example, LPT1 or USB).
Scans very slowly.	<ul style="list-style-type: none"> • Check if the machine is printing receiving data. Scan the document after the current job is completed. • Graphics are scanned more slowly than text. • Communication speed becomes slow in scan mode because of the large amount of memory required to analyze and reproduce the scanned image. <p>Set your computer to ECP printer mode through BIOS setting. It helps to increase the speed. For details on how to set BIOS, refer to your computer user documentation.</p>

Faxing problems

Problem	Possible cause and solution
 <p>Machine is not working, no display, and buttons are not working</p>	<ul style="list-style-type: none"> • Unplug the power cord and plug it in again. • Ensure that there is power to the electrical outlet.
<p>No dial tone</p>	<ul style="list-style-type: none"> • Check that the phone line is connected properly. • Check that the phone socket in the wall is working by plugging in another phone.
<p>Numbers stored in the memory do not dial correctly</p>	<p>Make sure that the numbers are stored in the memory correctly. Print a phonebook list.</p>
<p>Document does not feed</p>	<ul style="list-style-type: none"> • Make sure that the document is not wrinkled and you are putting it in correctly. • Check that the document is the correct size, not too thick or too thin. • Make sure that the ADF cover is firmly closed.
<p>Faxes are not received automatically</p>	<ul style="list-style-type: none"> • Make sure Receive mode is set to Automatic on the FAX SETUP menu. • Make sure that there is paper loaded. • Check that the display does not show MEMORY FULL.
<p>Machine does not send</p>	<ul style="list-style-type: none"> • Make sure that the document is loaded in the ADF or on the document glass. • Make sure the fax machine you are sending to can receive faxes.

Problem	Possible cause and solution
Incoming fax has blank spaces or is received with a poor quality	<ul style="list-style-type: none"> • Fax machine sending the fax may be faulty. • Fax machine sending the fax may have a dirty document glass. Clean the document glass. • Noisy phone line can cause line errors. • Check machine by making a copy. • Toner cartridge may be empty. Replace the toner cartridge.
Some of the words on a incoming fax are stretched	Fax machine sending the fax had a temporary jam.
There are lines on documents sent	Check your scan glass for marks and clean it.
Machine dials a number, but fails to make a connection with another fax machine	The other fax machine may be turned off, out of paper, or cannot answer incoming calls. Ask the receiving fax recipient to solve the problem.
Documents are not stored in memory	There may not be enough memory to store the document. If the display shows a MEMORY FULL message, delete any documents you no longer need from the memory, and then restore the document.
Blank areas appear at the bottom of each page or on other pages, with only a small strip of text printed at the top	The wrong paper settings may have been chosen.

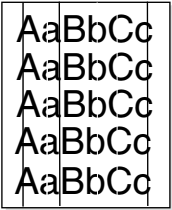
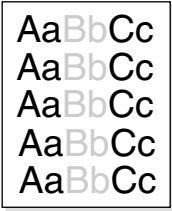

Print quality checks

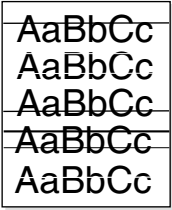
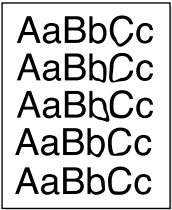
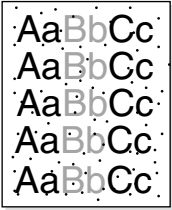
Problem	Possible causes
<ul style="list-style-type: none"> • Straight thin black vertical line and band • Dark black vertical bands 	<ul style="list-style-type: none"> • The drum inside the toner cartridge has probably been scratched. • Toner cartridge failure. • Foreign material between transfer/charge/development rollers. • Deformed transfer roller.
<ul style="list-style-type: none"> • Vertical white streak • Faded areas 	<ul style="list-style-type: none"> • The toner supply is low. Before changing the cartridge, try redistributing the toner or cleaning the photoconductor drum first. • Toner cartridge failure. <ul style="list-style-type: none"> Note: If dense paper is used or processing a lot of graphics, the cartridge may need changing more often. • Paper may not meet specifications (too moist or too rough). See “Paper and speciality media guidelines” on page 1-3 for more information. • If the entire page is light, adjust the darkness and content. See “Customizing settings” on page 3-18 for more information. • A combination of faded or smeared defects may indicate that the toner cartridge needs cleaning. See “Cleaning the photoconductor drum” on page 1-9 for more information. • Printhead failure. • Fuser failure. • Foreign material on printhead lens.

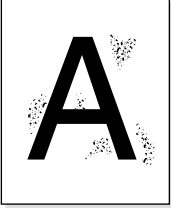
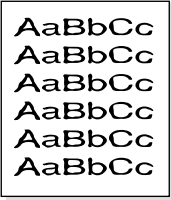
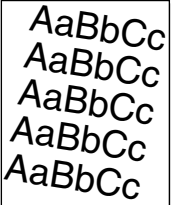
Problem	Possible causes
<p>Dark or blurry horizontal stripes</p> 	<ul style="list-style-type: none"> • Check the toner cartridge installation. • Toner cartridge may be defective. Toner cartridge failure. • Bad or dirty voltage contacts.
<p>Toner smear</p> 	<ul style="list-style-type: none"> • Clean inside printer. See “Cleaning the inside of the machine” on page 1-6 for more information. • Check paper type and quality. See “Selecting print materials” on page 1-2 for more information. • Toner cartridge failure. • Fuser failure.
<ul style="list-style-type: none"> • Dark or blurry black spots occur periodically • White spots occur periodically 	<ul style="list-style-type: none"> • Paper may not meet specifications (too moist or too rough). See “Paper and speciality media guidelines” on page 1-3 for more information. • Check paper path for debris. See “Cleaning the inside of the machine” on page 1-6 for more information. • Toner cartridge failure. • Transfer roller failure.

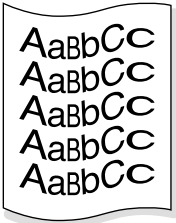
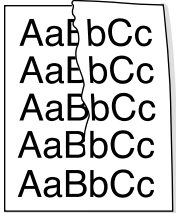
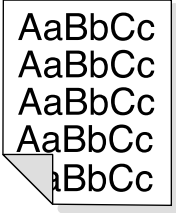
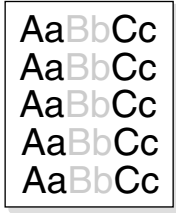
Problem	Possible causes
<p data-bbox="136 212 348 237">Background scatter</p> 	<ul data-bbox="466 212 949 548" style="list-style-type: none"> • Paper may be damp. Try printing with a different batch of paper. • Note: Paper does absorb moisture. Open paper packages when ready for use. • If background scatter occurs on an envelope, change printing layout to avoid printing over areas with overlapping seams on the reverse side. • If background scatter covers the entire surface area of a printed page, adjust the print resolution through a software program or the printer properties.
<p data-bbox="136 573 370 597">Misformed characters</p> 	<ul data-bbox="466 573 949 906" style="list-style-type: none"> • Paper stock may be too slick causing characters to be improperly formed and producing hollow images. See “Selecting print materials” on page 1-2 for more information. • Scanner unit may be defective causing characters to be improperly formed and producing a wavy effect. • Inspect the CCD unit for proper operation and movement. • Ensure the belt, which moves the CCD unit, is properly installed.
<p data-bbox="136 933 256 958">Page skew</p> 	<ul data-bbox="466 933 949 1182" style="list-style-type: none"> • Check paper type and quality. See “Selecting print materials” on page 1-2 for more information. • Ensure paper or other material is loaded correctly. • Ensure the guides are not too tight or too loose against the paper stack. See “Selecting print materials” on page 1-2 for more information.

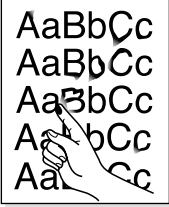
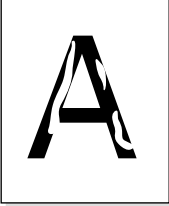
Problem	Possible causes
<p>Curl or wave</p> 	<ul style="list-style-type: none"> • Check paper type and quality. See “Selecting print materials” on page 1-2 for more information. • Note: High temperature and humidity can cause paper curl. • Turn over the stack of paper and rotate 180° in the tray.
<p>Wrinkles and creases</p> 	<ul style="list-style-type: none"> • Ensure the paper is loaded properly. • Check the paper type and quality. See “Selecting print materials” on page 1-2 for more information. • Turn over the stack of paper and rotate 180° in the tray.
<p>Back of printout is dirty</p> 	<ul style="list-style-type: none"> • Clean transfer roller. See “Cleaning the machine” on page 1-5 for more information. • Check for leaking toner. Clean inside the printer. See “Cleaning the inside of the machine” on page 1-6 for more information. • Fuser failure (dirty).
<p>Printed image is light, with no residual image</p> 	<ul style="list-style-type: none"> • Toner save mode on. • Toner cartridge failure. • Transfer roller failure. • Bad or dirty voltage contacts. • HVPS failure.

Problem	Possible causes
<p>Black or dark image</p> 	<ul style="list-style-type: none"> • Check that toner cartridge is installed properly. • Toner cartridge failure. • Bad or dirty high voltage contacts. • HVPS failure.
<p>Loose toner</p> 	<ul style="list-style-type: none"> • Clean the inside of the printer. See “Cleaning the inside of the machine” on page 1-6 for more information. • Check paper type and quality. See “Selecting print materials” on page 1-2 for more information. • Toner cartridge failure. • Check that correct media type is selected. • Fuser failure.
<p>Character voids</p> 	<p>White areas, within the parts of characters, that should be solid black.</p> <ul style="list-style-type: none"> • If transparencies are used, try another type of transparency. • Check that the printing is on the correct surface. Remove the paper and turn over in tray. • Check that paper meets paper specifications. See “Selecting print materials” on page 1-2 for more information.
<p>Print density is uneven from left to right</p> 	<ul style="list-style-type: none"> • Toner cartridge failure. • Improper transfer roller installation. • Transfer roller failure.

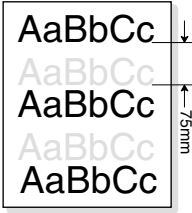
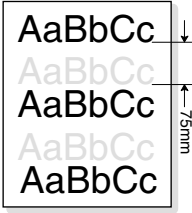
Problem	Possible causes
<ul style="list-style-type: none"> • Background appears in print area • Gray background 	<ul style="list-style-type: none"> • Check for recommended paper weight (recycled or poor quality paper). See “Selecting print materials” on page 1-2 for more information. • Check machine environment. • Toner cartridge failure. <p>Note: Very dry (low humidity) or humid (higher than 80% relative humidity (RH)) conditions can increase background shading.</p> <ul style="list-style-type: none"> • Dirty transfer roll. • Transfer roll failure or improperly installed. • HVPS failure.
<p>Residual image occurs at 75 mm intervals</p> 	<ul style="list-style-type: none"> • Toner cartridge failure. • Bad or dirty high voltage contacts. • Transfer roller failure. • Engine board failure.
<p>Residual image occurs at 75 mm intervals when printing card stock or transparencies</p> 	<p>Software not set to card stock or transparency mode.</p>

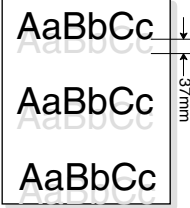
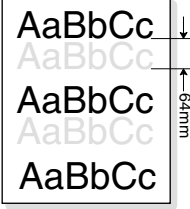
Problem	Possible causes
<p>Residual image occurs in the black image printing at 37 mm intervals</p> 	<ul style="list-style-type: none"> • Toner cartridge failure. • Bad or dirty high voltage contacts.
<p>Residual image occurs at 64 mm intervals</p> 	<ul style="list-style-type: none"> • Fuser temperature maintained too high. Check for toner buildup on hot roller and thermistor surface. • Clean or replace fuser if necessary.

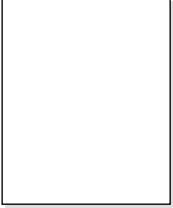
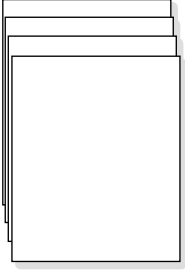
<p style="text-align: center;">Problem</p>	<p style="text-align: center;">Possible causes</p>
<p>Blank page prints</p> 	<ul style="list-style-type: none"> • Redistribute the toner. • If necessary, replace the toner cartridge. • Ensure the printed file doesn't have blank pages. • Bad or dirty high voltage contacts; inspect and clean contacts. • Replace the LVPS/HVPS. • Replace the system board.
<ul style="list-style-type: none"> • Blank page prints • One or several blank pages print • When printer is powered on, several blank pages print 	<ul style="list-style-type: none"> • Bad or dirty high voltage contacts. • Pick roller solenoid failure. • System board failure.

If an abnormal image prints periodically, check the following parts:

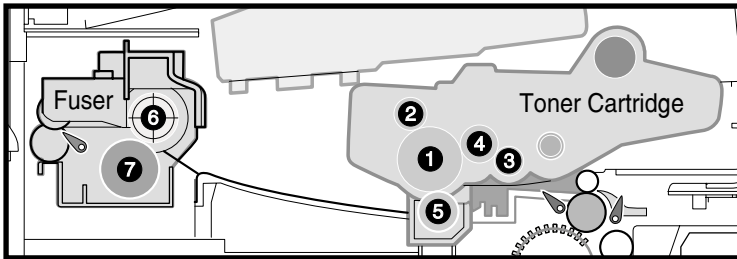

No.	Distance between repeated marks	Related printer components	Type of abnormal image	Replace
1	75.5 mm	OPC drum	White or black spots/voids	Toner cartridge
2	37.7 mm	Charge roller	Black spots	Toner cartridge
3	37.0 mm	Supply roller	Horizontal shock lines	Toner cartridge
4	35.2 mm	Developer roller	Horizontal shock lines	Toner cartridge
5	45.3 mm	Transfer roller	Back side contamination	Transfer roller
6	64.1 mm	Hot roll	White or black spots/voids	Fuser
7	75.5 mm	Back-up roller	Back side contamination	Fuser

Service checks

Cooling fan

FRU	Action
 <p>Cooling fan, LVPS/HVPS, system board</p>	<ul style="list-style-type: none"> • Perform the “Motor, Fan, Solenoid test” on page 3-10 to see if the fan turns on. • If the fan turns on, the problem is likely associated with the system board. • If the fan does not turn on, make sure the cooling fan cable is properly seated in CN3 on the LVPS/HVPS. • Disconnect the fan, and check CN3-1 for +24 V dc. • If the voltage is present, replace the cooling fan. • If the voltage is not present, replace the LVPS/HVPS.

Main drive motor

FRU	Action
 <p>Main drive motor, system board, LVPS/HVPS</p>	<ul style="list-style-type: none"> • Perform the “Motor, Fan, Solenoid test” on page 3-10 to see if the main drive motor turns on. • If the motor works but is noisy, replace the main drive assembly. • If the motor works correctly in this test but not during normal printing, the problem may be associated with a faulty system board. • If the motor does not work at all during this test, make sure the motor cable is properly connected. • If connections are correct and the problem persists, replace the main drive assembly. • If the problem persists, replace the LVPS/HVPS.

Document cover open switch

FRU	Action
<p>Document cover switch, operator panel</p>	<ul style="list-style-type: none"> • First, make sure the document cover open switch cable is properly seated in CN1 on the operator panel. • Disconnect the cable from CN1 on the operator panel and check CN1-1 for +5 V dc. • If the voltage is present, the document cover switch is faulty. • If the voltage is not present, replace the operator panel.

**Dead machine**

FRU	Action
Line voltage	Check the AC line voltage to make sure it is correct.
LVPS/HVPS to system board cable	Ensure the cable connecting the LVPS/HVPS to the system board is properly seated.
LVPS/HVPS	<p>Check the following voltages on CN2 of the LVPS/HVPS:</p> <ul style="list-style-type: none"> • pin 3, +5 V dc • pin 4, +5 V dc • pin 5, Ground • pin 6, Ground • pin 7, +12 V dc • pin 8,9,10,11, Ground • pin 12, +24 V dc <p>If any of the voltage measurements are not correct, replace the LVPS/HVPS.</p>

Operator panel, scanner card assembly

FRU	Action
Operator panel scanner card assembly	<ul style="list-style-type: none">• Perform the “Operator Panel test” on page 3-12 to check for proper operation of the LCD screen, LED(s) and key buttons.• If the operator panel does not work at all, check the following on the scanner card:<ul style="list-style-type: none">– CN2-1, Ground– CN2-2, +5 V dc• If the voltage is not present, replace the scanner card.• If the voltage is present, check for continuity of the operator panel cable.• If continuity is missing in any part of the cable, replace the cable.• Otherwise, replace the operator panel.

4038-001

3. Diagnostic aids

Configuration modes

Clear All Memory mode

The Clear All Memory setting is used to reset all settings back to factory defaults.

Note: Page counts are not reset when Clear All Memory is performed.

To adjust Clear All Memory:

1. Press **Menu, #, 1, 9, 3, 4**.
The LCD displays TECH.
2. Press **Menu**, and then **Select**.
3. Select **Data Setup**.
4. Select **Clear All Memory**.
5. Select the country where the machine is located and press **Select** to save the setting.
6. Press **Return** to go back to TECH screen.
7. Press **Menu, #, 1, 9, 3, 4** to exit TECH mode.

Dial mode

The Dial mode setting allows the modem card to be changed between pulse or tone dial modes.

To adjust Dial mode:

1. Press **Menu, #, 1, 9, 3, 4**.
The LCD displays TECH.
2. Press **Menu**, and then **Select**.
3. Select **Data Setup**.
4. Select **Dial mode**.
5. Use the arrow keys to select the desired dial mode.
6. Press **Select** to save the setting.
7. Press **Return** to go back to TECH screen.
8. Press **Menu, #, 1, 9, 3, 4** to exit TECH mode.

Error Rate mode

The Error Rate setting is a level used to automatically lower the modem speed when errors occur. Whenever the error rate exceeds this setting the baud rate of the modem card automatically drops to 2400 bps. This setting can be set at 5% or 10%.

To adjust the Error Rate:

1. Press **Menu, #, 1, 9, 3, 4**.
The LCD displays TECH.
2. Press **Menu**, and then **Select**.
3. Select **Data Setup**.
4. Select **Error Rate**.
5. Select the desired error rate value (5% or 10%) and press **Select** to save the setting.
6. Press **Return** to go back to TECH screen.
7. Press **Menu, #, 1, 9, 3, 4** to exit TECH mode.

Modem Speed mode

The Modem Speed setting is used to select the modem speed. The possible choices are:

- 4.8
- 9.6
- 12.0
- 14.4
- 28.8
- 33.6 Kbps.

To adjust the Modem Speed:

1. Press **Menu, #, 1, 9, 3, 4**.
The LCD displays TECH.
2. Press **Menu**, and then **Select**.
3. Select **Data Setup**.
4. Select **Modem Speed**.
5. Select the desired modem speed value and press **Select** to save the setting.
6. Press **Return** to go back to TECH screen.
7. Press **Menu, #, 1, 9, 3, 4** to exit TECH mode.

Park CCD module mode

This function parks the CCD module in the middle of the flatbed to prevent damage to the CCD module during shipping. Perform this function whenever the printer is to be shipped.

To park the CCD module:

1. Press **Menu, #, 1, 9, 3, 4.**

The LCD screen displays TECH.

2. Press **Menu**, and then **Select**.
3. Select **Machine Test**.
4. Select **Move CCD**.

The CCD module parks in the shipping position.

5. At this point, the printer can be powered off and packaged for shipping.

Note: Once the power is turned back on, the CCD module returns to a normal position.

6. To return the CCD module without powering off the machine, lift the document cover and then lower document cover.

Print Properties mode

Settings to adjust for a print job include:

- **Orientation** - the direction information is printed on a page.
- **2-UP or 4-UP** - multiple pages printed on one sheet.
- **Scale** - the size information is printed on a page.
- **Fit to Page** - used to fit a document to a selected paper size.
- **Watermark** - text printed over an existing document.
- **Overlay** - specific text or images printed on multiple documents, such as the text or images that make up a letterhead.
- **Odd/Even pages and Manual feed** - used to print on both sides of the paper.

Access Print Properties using the program or the Printers folder.

Note:

- Accessing Print Properties from the program, any settings changed are in effect only while using the current program.
- Accessing Print Properties from the Printers folder, any settings changed are permanent.

Print settings description

From this tab:	Change these settings:
Layout	<p>Orientation - select how the document is oriented on the printed page.</p> <p>Layout - select the type of layout for the document.</p>
Paper	<p>Copies - select the number of copies to print.</p> <p>Type - select the type of paper to use. Make sure that Type is set to Printer Default. If you load specialty media, select the corresponding paper type. For more information see the <i>User's Guide</i>.</p> <p>Source - select the paper input source (front input tray or manual bypass). The Manual Feed source is used when printing specialty media. Load one sheet at a time into the manual bypass. If the paper source is set to Auto Select, the machine automatically picks up print materials from the manual bypass first, and then the paper tray.</p> <p>Size - select the size of paper to use.</p>
Graphics	<p>Resolution - select the quality of the output (600 dots per inch (dpi) for normal quality or 300 dpi for draft quality).</p>
Extras	<p>Watermark - select the text to print over an existing document.</p> <p>Overlay- select a one-page document containing text or graphics to print over another document.</p>

Send Level mode

The Send Level setting adjusts the transmission signal level of the modem card. Typically, this level should be under 12dB.

Note: The Send Level is set at the factory at an optimal setting. Do not arbitrarily adjust.

To adjust Send Level:

1. Press **Menu, #, 1, 9, 3, 4**.
The LCD displays TECH.
2. Press **Menu**, and then **Select**.
3. Select **Data Setup**.
4. Select **Send Level**.
5. Key in desired send level (9–15) and press **Select**.
6. Press **Return** to go back to TECH screen.
7. Press **Menu, #, 1, 9, 3, 4** to exit TECH mode.

System Settings Report mode

This function prints a listing of all configuration settings, code version levels, and page counts.

To print a System Settings report:

1. Press **Menu, #, 1, 9, 3, 4**.
The LCD screen displays TECH.
2. Press **Menu**, and then **Select**.
3. Select **Report**.
4. Select **System Data**.
5. A system settings page prints.
6. Press **Menu, #, 1, 9, 3, 4** to exit TECH mode.

Machine tests

DRAM Memory test

The DRAM Memory test checks all DRAM memory on the system board.

To enter the DRAM Memory test:

1. Press **Menu, #, 1, 9, 3, 4**.

The LCD screen displays TECH.

2. Press **Menu**, and then **Select**.
3. Select **Machine Test**.
4. Select **DRAM Test**.

The test runs automatically.

- If the test passes, the LCD screen displays OK.
- If the test fails, an error message displays.

Replace the system board if the DRAM Memory test fails.

5. Press **Return** to exit the test.
6. Press **Menu, #, 1, 9, 3, 4** to exit TECH mode.

Modem Protocol Log test

The Modem Protocol log prints the sequence of the CCITT group 3 T.30 protocol during the most recent sending or receiving operation. This report is used to check for send and receive errors.

To perform the Modem Protocol log:

1. Press **Menu, #, 1, 9, 3, 4.**

The LCD screen displays TECH.

2. Press **Menu**, and then **Select**.
3. Select **Machine Test**.
4. Select **Report**.
5. Select **Protocol**.

A Modem Protocol log page prints.

6. Press **Menu, #, 1, 9, 3, 4** to exit TECH mode.

Modem test

The Modem test causes the modem to send various transmit signals on the telephone line. The signals are audible through the speaker.

To enter the Modem test:

1. Press **Menu, #, 1, 9, 3, 4.**

The LCD screen displays TECH.

2. Press **Menu**, and then **Select**.
3. Select **Machine Test**.
4. Select **Modem Test**.
5. Select the baud rate to test.
6. Press **Select** to begin the test.
7. Press **Return** to end the test.
8. Press **Stop/Clear** twice to exit the test.
9. Press **Menu, #, 1, 9, 3, 4** to exit TECH mode.

Motor, Fan, Solenoid test

This test checks the following components:

- Main drive motor
- Paper tray pick-up solenoid
- Cooling fan
- Main feed roller/bypass solenoid
- Pre-transfer LED

To enter the Motor, Fan, Solenoid test:

1. Press **Menu, #, 1, 9, 3, 1.**
2. Select **Diagnostic.**
3. Press **Select** for **Mtr Fan Sol.**

Each component is listed one at a time. The first component is the main drive motor.

4. To test the component, press 1.
5. To turn off the component test and proceed to the next component test, press 2.

The test can be exited at any time by pressing Return.

Note: If a component was activated when Return is pressed, that component remains activated while another test can run concurrently.

6. Press **Stop/Clear** to exit the Diagnostic Test mode.

Operator Panel Button test

The Operator Panel Button test checks all key buttons on the operator panel.

To enter the Operator Panel Button test:

1. Press **Menu, #, 1, 9, 3, 4.**

The LCD screen displays TECH.

2. Press **Menu**, and then **Select**.
3. Select **Machine Test**.
4. Select **Switch Test**.
5. Press the desired key button(s), one at a time, to perform the test.

As a key button is pressed, the LCD screen displays the name of the key button.

6. Press **Stop/Clear** twice to exit the test.
7. Press **Menu, #, 1, 9, 3, 4** to exit TECH mode.

Operator Panel test

To perform the Operator Panel test:

1. Press **Menu, #, 1, 9, 3, 8**.
2. Press, **Select**
3. Select LCD LED Key.
4. Press any key to begin the LCD test.
 - Each pel of the LCD panel is illuminated, starting from left to right. Once all pels have been illuminated, press any key. All LEDs now illuminate.
5. Press **Menu** to perform the LED test.
 - The light contrast LED turns off. By continuing to press any key, each LED turns off. When the last LED is turned off, the Key Button test begins.
6. Press each key button prompted by the LCD screen to verify that each button is working.

Note: If you press a button other than the one prompted, a series of beeps is audible.

- After each key button has been pressed, the LCD screen indicates that the test is complete.
- If any of the LCD pels do not illuminate, any of the LEDs do not illuminate, or any of the key buttons do not work, replace the operator panel.

Printhead test

The Printhead test checks the following components:

- Printhead motor
- Printhead HSYNC
- Laser diode

To enter the Printhead test:

1. Press **Menu, #, 1, 9, 3, 1**.
2. Select **Diagnostic**.
3. Press **Menu**, and then select **LSU test**.
4. Press **Select**.

Each component is listed one at a time. The first component is the printhead (LSU) motor.

5. To test the component, press **1**.

The LCD screen displays Ready once the component passes the test.

6. To turn off the component test and proceed to the next component test press **2**.

The test can be exited at any time by pressing Return.

Note: If a component was activated when Return is pressed, that component remains activated while another test can run concurrently.

7. Press **Stop/Clear** to exit the Diagnostic test mode.

Print Quality Pages test

This function prints a variety of test pages used to verify print quality. There are seven different test patterns.

Pattern	Description
1	Graphics / image quality
2	Graphics / image quality
3	Horizontal lines
4	White page
5	Dot array (fine)
6	Dot array (coarse)
7	Vertical lines

To perform the Print Quality Pages test:

1. Press **Menu, #, 1, 9, 3, 4.**

The LCD screen displays TECH.

2. Press **Menu,** and then **Select.**
3. Select **Machine Test.**
4. Select **Pattern Test.**
5. Select the pattern to print, or select All to print all test patterns.
Select the number of pages to be printed per test at the print no. prompt.
6. Press **Menu, #, 1, 9, 3, 4** to exit TECH mode.

ROM Memory test

The ROM Memory test checks the ROM memory in the printer.

To enter the ROM Memory test:

1. Press **Menu, #, 1, 9, 3, 4**.

The LCD screen displays TECH.

2. Press **Menu**, and then **Select**.
3. Select **Machine Test**.
4. Select **ROM Test**.

The test runs automatically.

- If the test passes, the flash and engine code levels are displayed on the LCD screen.
 - If the test fails, replace the system board.
5. Press **Return** to exit the test.
 6. Press **Menu, #, 1, 9, 3, 4** to exit TECH mode.

Scanner CCD Module and Motor test

This test is used to check for proper movement of the CCD module from one side of the flatbed scanner to the other.

To perform the scanner CCD tests:

1. Press **Menu, #, 1, 9, 3, 8**.
2. Press the right arrow key to select scanner.
3. Press **Select**.
4. Press **Start** to begin the test.
 - During this test the CCD module moves continuously from side to side.
 - If the CCD does not move smoothly, or not at all, check that the belt is properly installed between the motor pulley and CCD module.
 - Ensure the CCD module is installed correctly.
 - If the CCD module strikes the left side of the scanner, the CCD module is not sensing its home position. This can be caused by a faulty CCD module cable, or the home position sensor which is part of the CCD module assembly.
5. Press **Stop**, at any time, to stop the test.

Sensor test

The Sensor test checks the following components:

- Main paper feed/toner cartridge present sensor
- Fuser exit sensor
- Toner cartridge access cover open sensor
- Paper tray empty sensor
- Manual bypass sensor

To enter the Sensor test:

1. Press **Menu, #, 1, 9, 3, 1**.
2. Select **Diagnostic**.
3. Press **Menu**, and then select **Sensor Test**.
4. Press **Select**.
5. Each sensor is tested one at a time.

The first sensor checked is the main paper feed/toner cartridge present.

6. Manually actuate the sensor flag while pressing **1** on the operator panel.

The LCD screen briefly posts On or Off depending on the position of the sensor actuator when 1 is pressed.

7. Press **2** to move to the next sensor to be tested.

The test can be exited at any time by pressing **Return**.

Note: If a component was activated when Return is pressed, that component remains activated while another test can run concurrently.

8. Press **Stop/Clear** to exit the Diagnostic test mode.

Note: While the toner cartridge is removed, the main paper feed/toner cartridge present sensor posts an On message when the actuator is fully up or down. With the cartridge installed, an Off message is posted. This sensor detects both paper jams and cartridge present.

Note: There are two tests on the Lexmark X215 MFP LCD that are not used in servicing this printer.

- Heat test
- HVPS test

Customizing settings

All the copy options (content, darkness, number, scale, and advanced) using the operator panel buttons can be temporarily modified. Settings remain in effect until a predefined time-out period is expired.

Note:

- Make all of your selections before pressing Start.
- Press Stop/Clear while modifying the copy settings cancels all settings for the current job and returns them to their default status.

Content

The content setting is used to improve copy quality. Choose from the following settings:

- **Text** - use for documents containing mostly text.
- **Mixed** - use for documents with mixed text and graphics.
- **Photo** - use when the originals are photographs.

To select, press **Content** repeatedly.

Each time you press Content, the LED labeled with the selected mode lights up.

Note: When you copy a document with color in the background using the Mixed mode, the machine automatically removes the background color. If you want to include the background color in your copy, load the document about 5 mm away from the edges of the scanning bed, or change the darkness setting.

Darkness

The darkness setting is used for an original document containing paint markings or dark images:

- **Light** - works well with dark print.
- **Normal** - works well with standard typed or printed documents.
- **Dark** - works well with light print or faint pencil markings.

To adjust the darkness, press **Darkness** repeatedly.

Each time you press the button, the LED labeled with the selected mode lights up.

Number

Select number of copies from 1 to 99.

1. Press **Number**.
2. Enter the number of copies to print using the numeric keypad.
3. Press **Select**.

The selected number appears on the display.

Scale

Original documents copied from the document glass, can be reduced or enlarged from 25% to 400%.

Original documents copied from the ADF, can be reduced or enlarged from 25% to 100%.

To scale a document to a pre-defined copy size:

1. Press **Scale**.

The default setting appears on the bottom line of the display.

2. Press a scroll button (◀ or ▶) repeatedly until the copy size is displayed.
3. Press **Select**.

To customize the copy size:

1. Press **Scale**.
2. Press a scroll button (◀ or ▶) until CUSTOM:25–400% (or CUSTOM:25–100%) appears on the bottom line of the display.
3. Press **Select**.
4. Enter the size using the numeric keypad.
5. Press **Select**.

The selected number appears on the display.

Advanced

The advanced option, copies images onto a page in a variety of layouts.

The advanced settings available when a document is loaded in the ADF include:

- Off - turns off the advanced copy features.
- Collation - controls the sequence in which multiple page documents are printed.
- 2-Up - prints two copied documents on a single page.
- 4-Up - prints four copied documents on a single page.

The advanced settings available when a document is loaded in the scanner bed include:

- Off - turns off the advanced copy features.
- Auto Fit - automatically reduces or enlarges the original image so the resulting copy fits on the paper.
- 2-Side - prints two copied documents on a single page. When using the scanner bed, the 2-Side feature is especially useful when copying both sides of an original document.

Note: Auto Fit and 2-Side can be selected only when the paper size is letter, legal, or A4.

To select the advanced setting:

1. Press **Advanced** repeatedly until the desired setting appears.
2. Press **Select**.

4038-001

4. Repair information



CAUTION: When you see this symbol, there is a danger from hazardous voltage in the area of the product where you are working. Unplug the product before you begin, or use caution if the product must receive power in order to perform the task.

Removals

Covers

Cartridge access cover removal

1. Remove the paper tray.
2. Open the access cover.



4038-001

3. Press in on one side of the access cover to release it.



4. Release the other side of the access cover and remove.

Middle cover removal

1. Remove the scanner and scanner card assembly. See **“Scanner assembly removal” on page 4-64**, and **“Scanner card assembly removal” on page 4-68** for more information.
2. Slip the cables out of the middle cover (A) (scanner to system board).

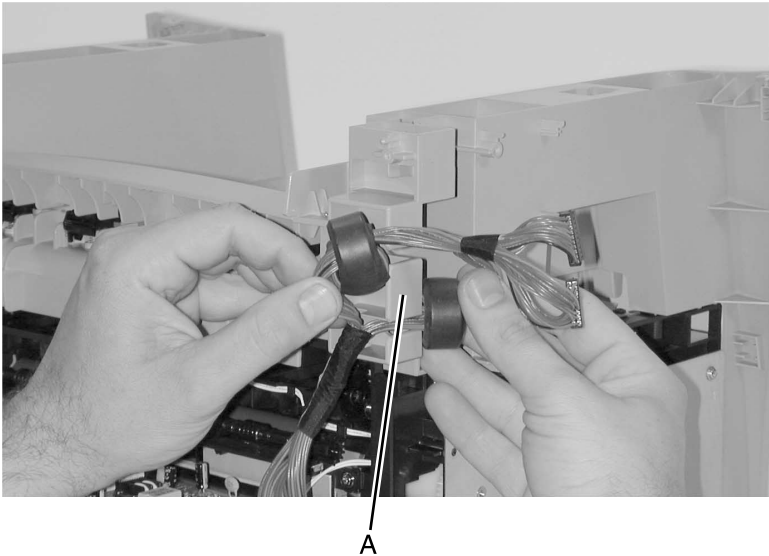

3. Remove six screws (A) in the middle cover.

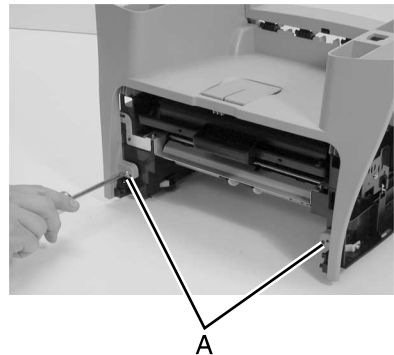
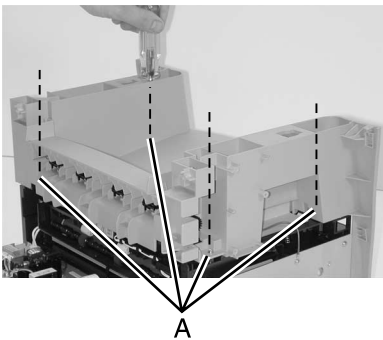

4038-001

4. From the front of the printer, pull both the middle cover legs away from the printer to release tabs.

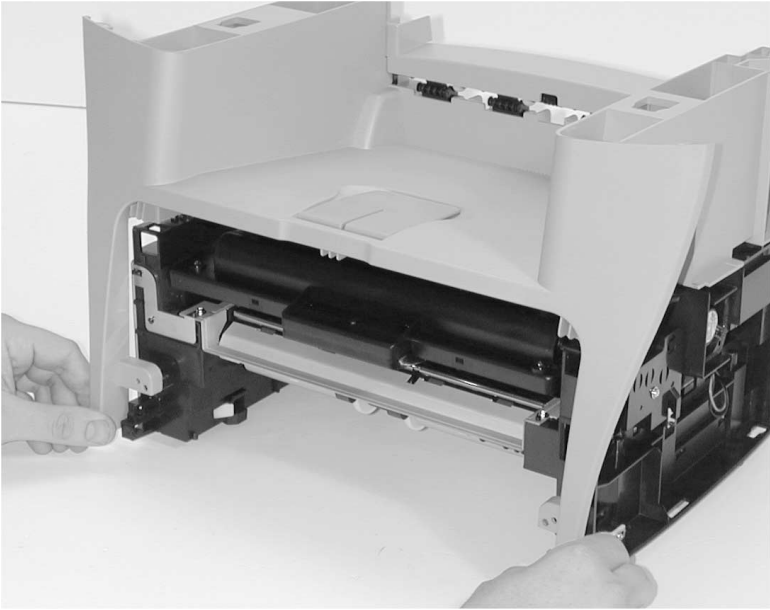

5. Lift up to remove the middle cover.





Rear cover removal

1.Remove four screws (A).



A

4038-001

2. Pull the rear cover to remove.



Scanner assembly document cover removal

1. Remove the left side cover. See **“Left side” on page 4-12** for more information.
2. Remove the ground screw on the drive assembly. See **“Scanner assembly removal” on page 4-64** for more information.
3. Disconnect the scanner assembly cable (A) (CN3).

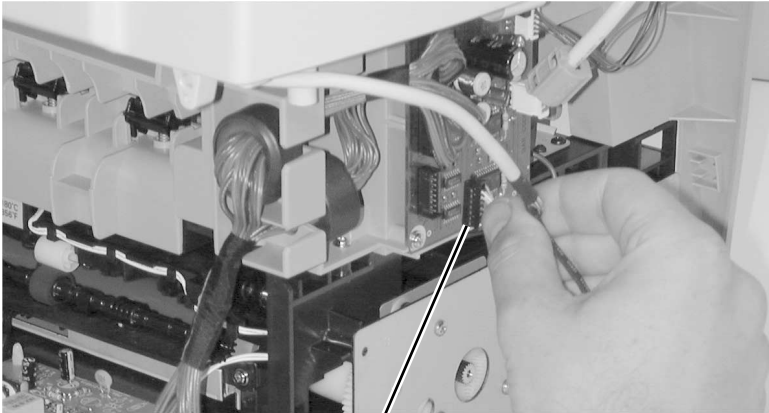

A

4. Un-thread the cable (A) from the scanner document cover.

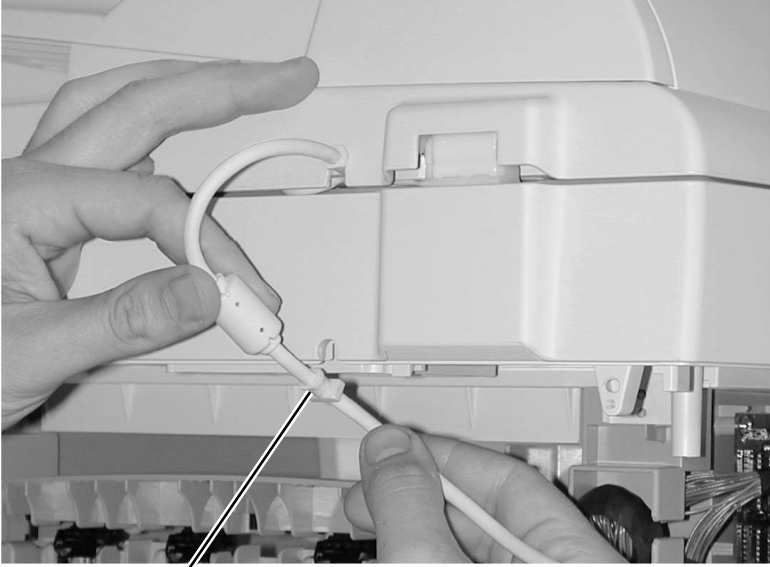

A

5. Open the document cover.

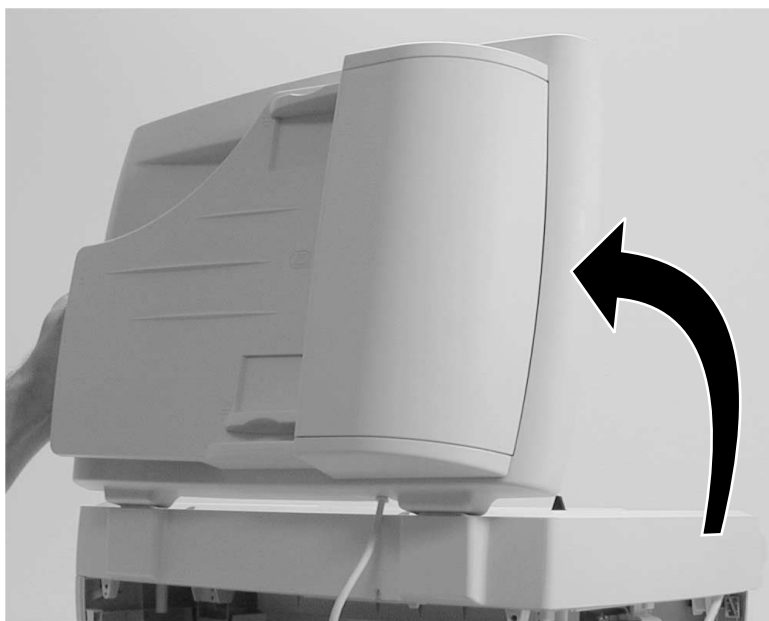

6. Lift the document cover until the hinges catch (A).



7. Tilt back and lift off the scanner document cover.





Side cover removals

Left side

1. Remove the rear cover. See **“Rear cover removal”** on **page 4-5** for more information.
2. Disconnect the speaker cable (A).

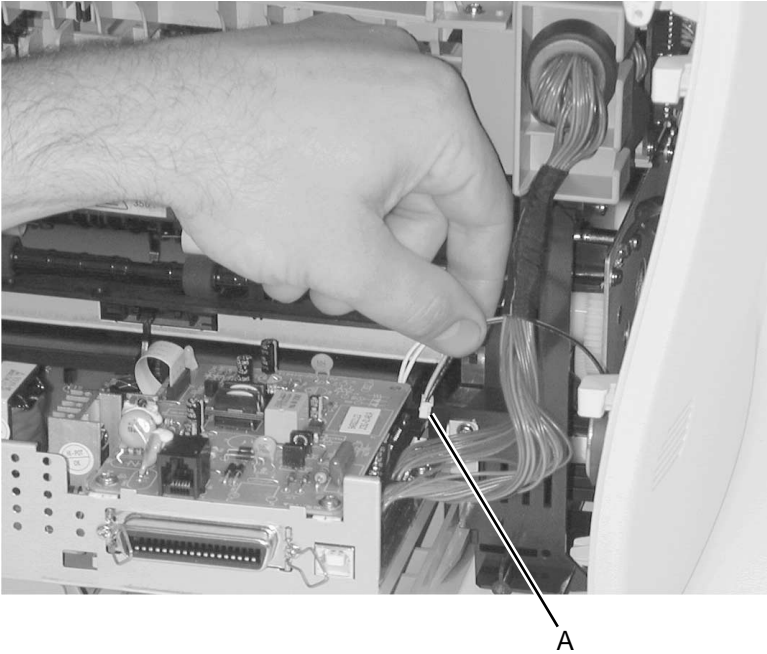

3. Slide the cover toward the rear of the printer to release.



4. Tilt away from printer.

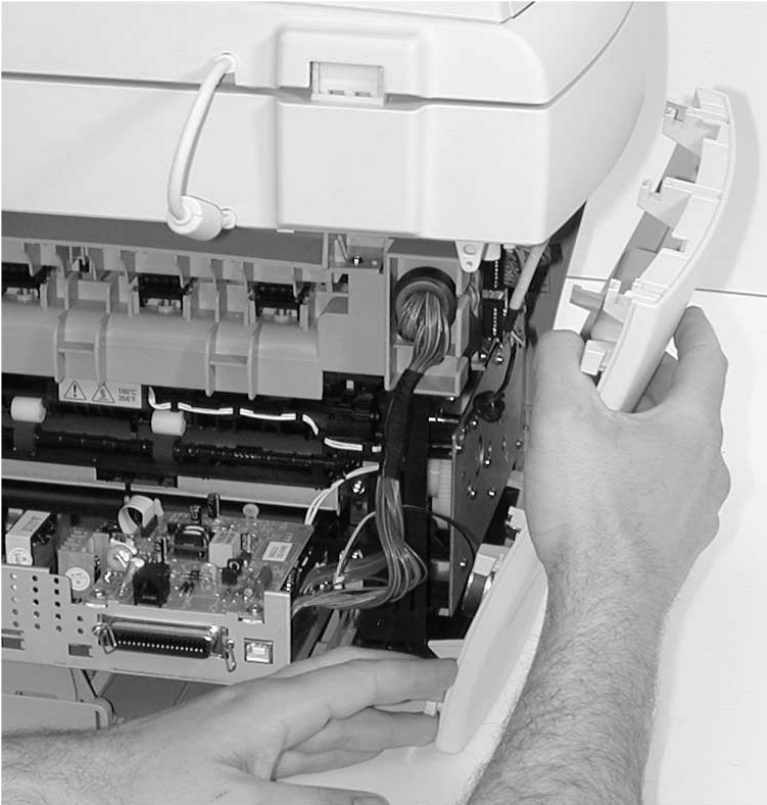

5. Lift to remove the left side cover.

**Right side**

1. Remove the rear cover. See **“Rear cover removal”** on **page 4-5** for more information.
2. Slide the cover toward the rear of the printer to release.



3. Tilt away from printer.

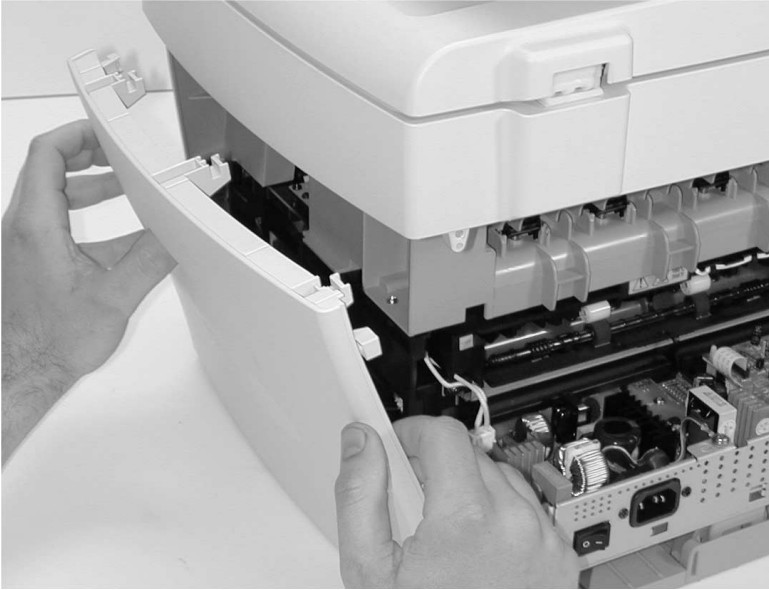

4. Lift to remove the right side cover.

Automatic document feed (ADF) removals

ADF Pick roller

1. Open ADF access cover.

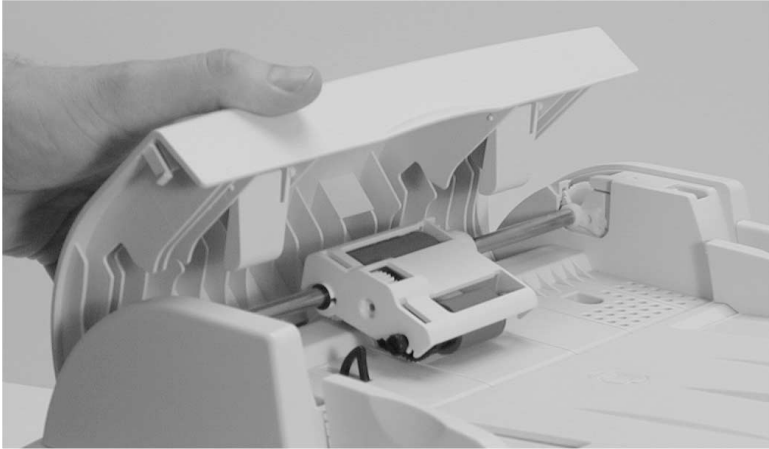

2. Rotate the pick roller bearing (A) to release from the ADF housing.

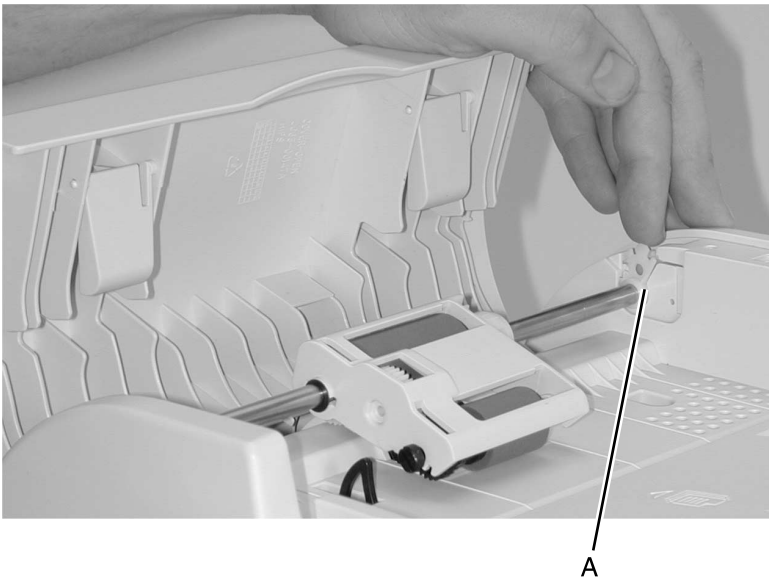

4038-001

3. Lift the pick roller and slide out.



ADF Pad

1. Remove the ADF pick roller. See **“Automatic document feed (ADF) removals”** on page 4-17 for more information.
2. Grab both sides of the ADF pad and lift.



CCD module assembly removal

1. Remove the scanner assembly and operator panel. See **“Scanner assembly removal”** on page 4-64, and **“Operator panel removal”** on page 4-50 for more information.
2. Remove four screws (A).

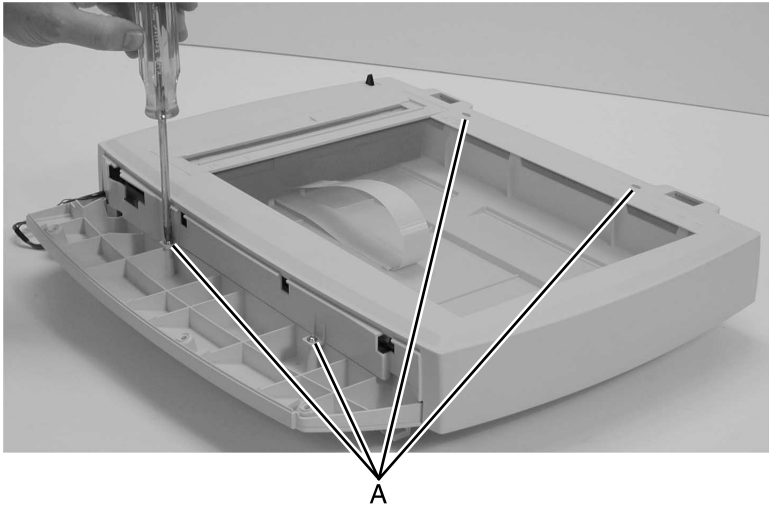

3. Slip a flat blade screwdriver under one side then the other to release the tabs.

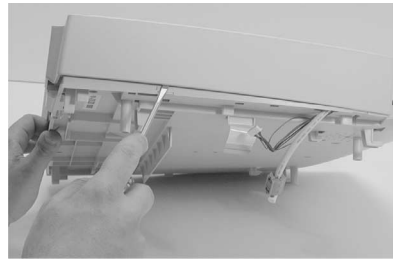
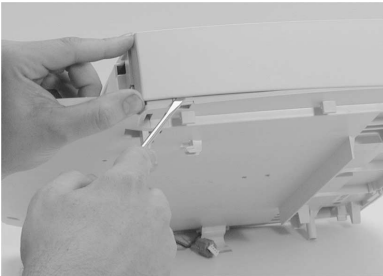

4038-001

4. Lift off glass housing to remove.

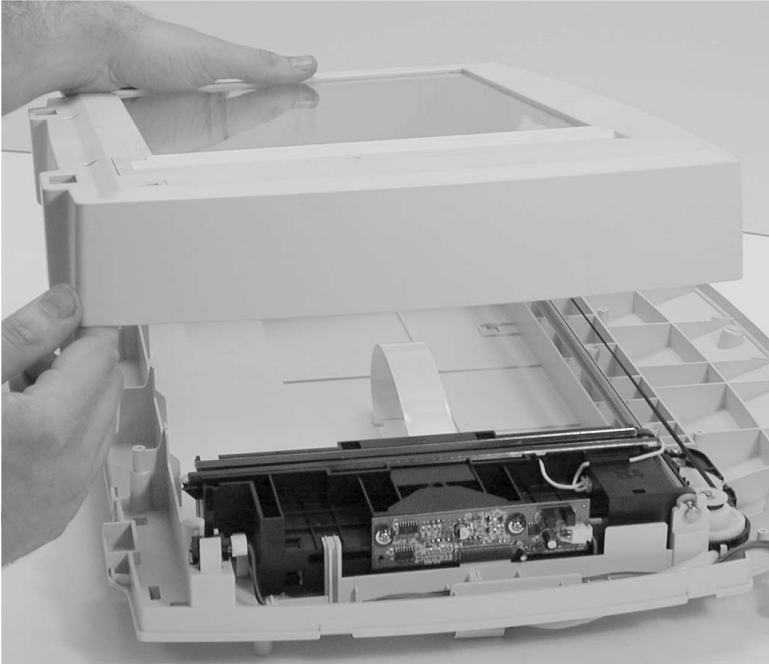

5. Use a flat blade screwdriver to gently pry open the CCD module assembly housing to release the belt.

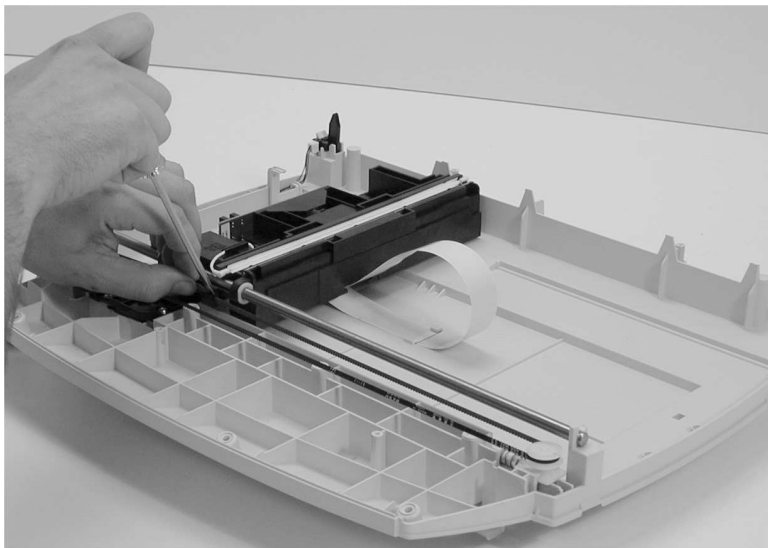

6. Pry the shaft loose on both ends and slide out.

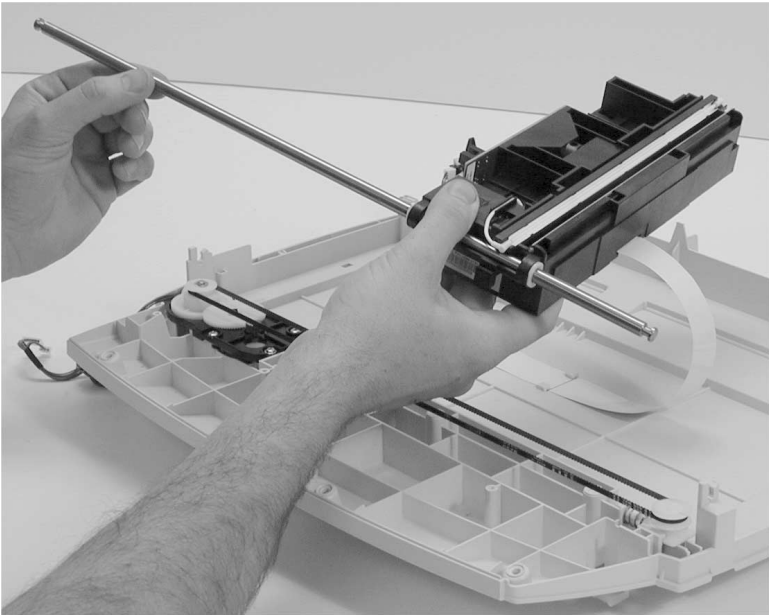
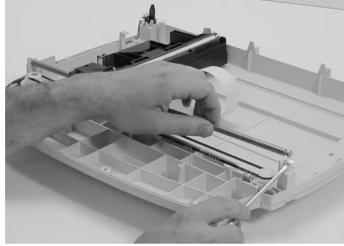

7. Release the ribbon cable from slots (A).

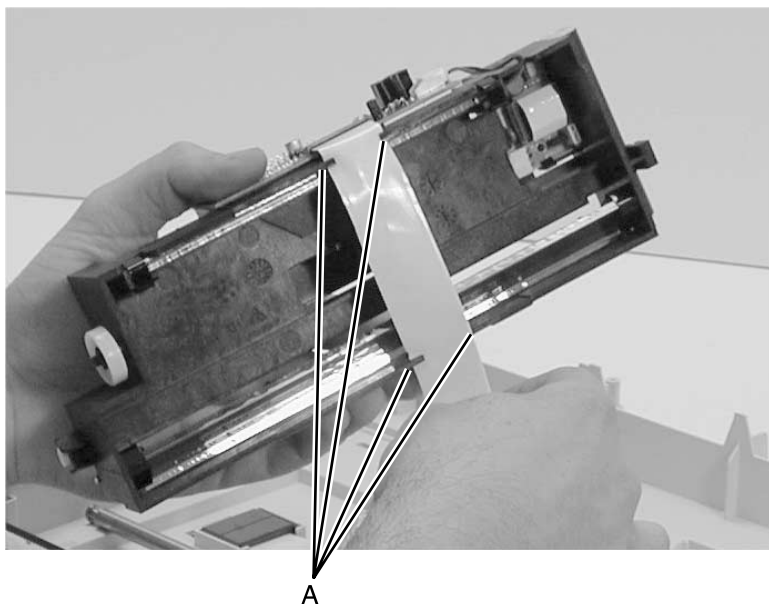

8. Disconnect the ribbon cable (A) from the CCD.

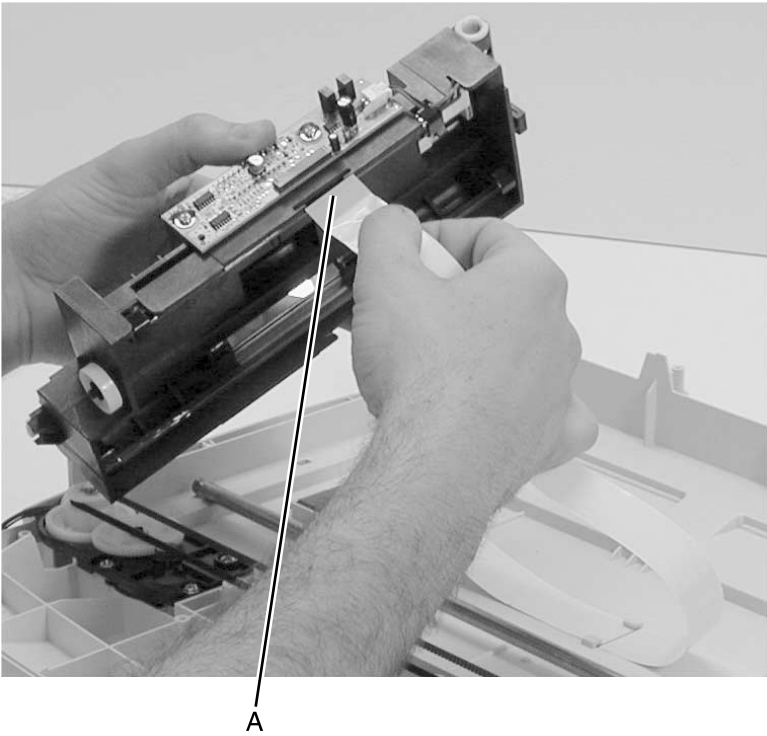

9. Remove the CCD assembly.



Card cage removal

1. Remove the left, right and rear covers. See **“Left side” on page 4-12**, **“Right side” on page 4-15**, and **“Rear cover removal” on page 4-5** for more information.
2. Remove two screws (A) at the rear of the printer.

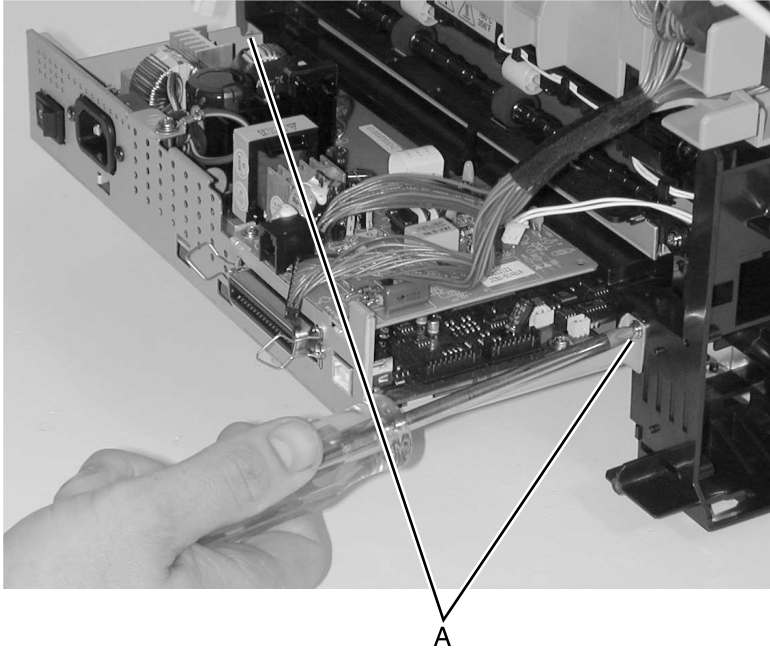

3. Place the printer front side down on a flat surface

4. Remove 10 screws (A) in card cage.

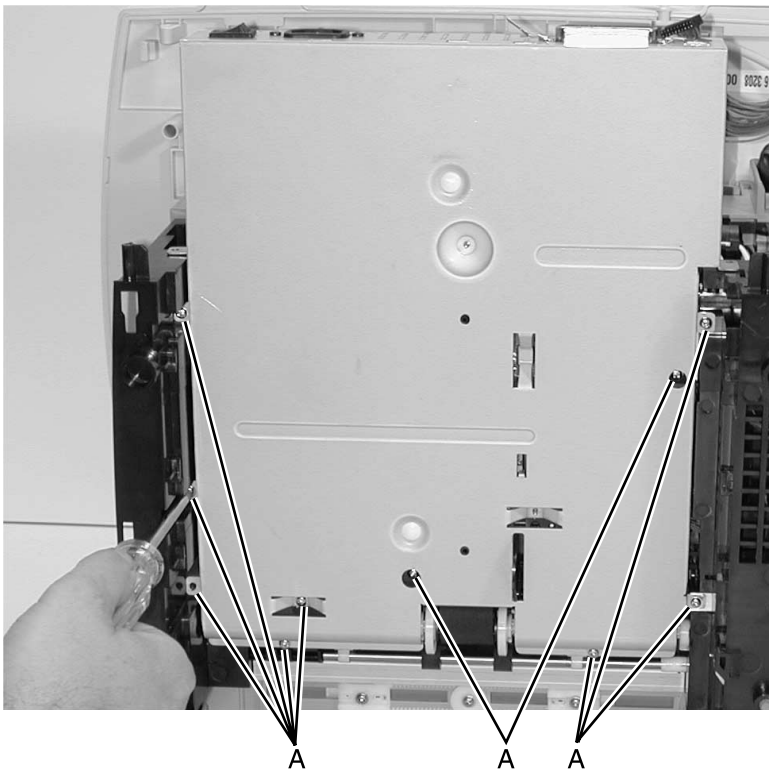

Note: Hold the card cage as you remove the last screw; as the cage can fall.

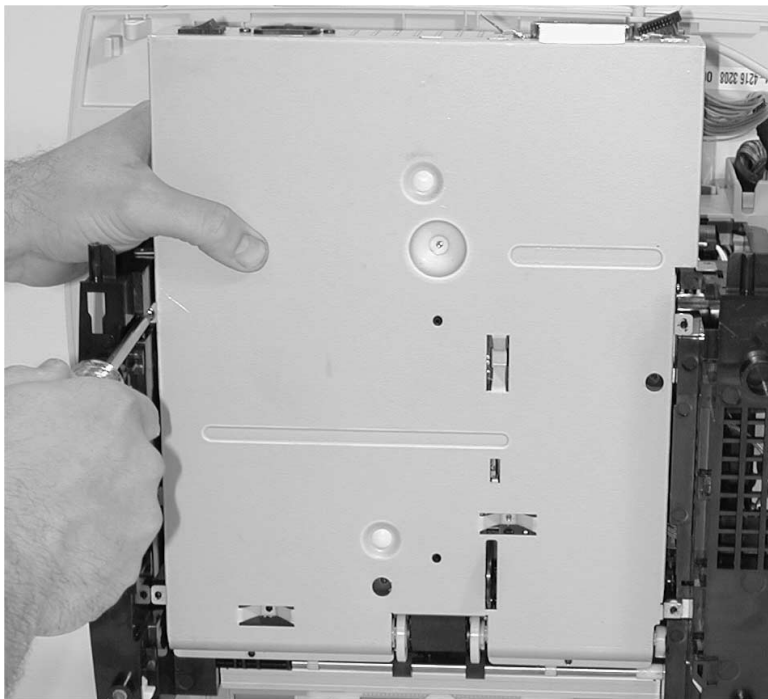

4038-001

5. Lift the card cage to remove.

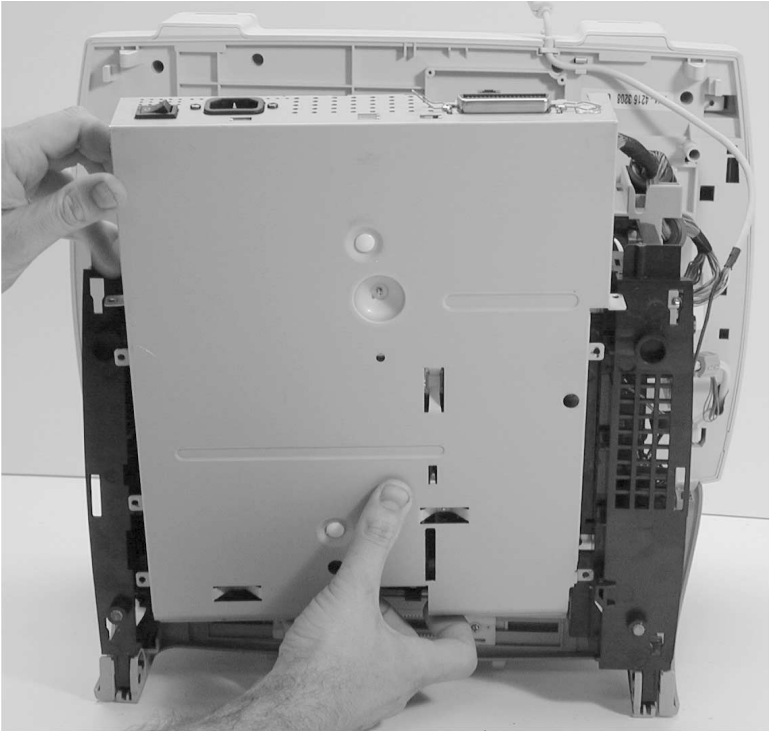

6. Disconnect all cables on the system board.
See reinstallation note.

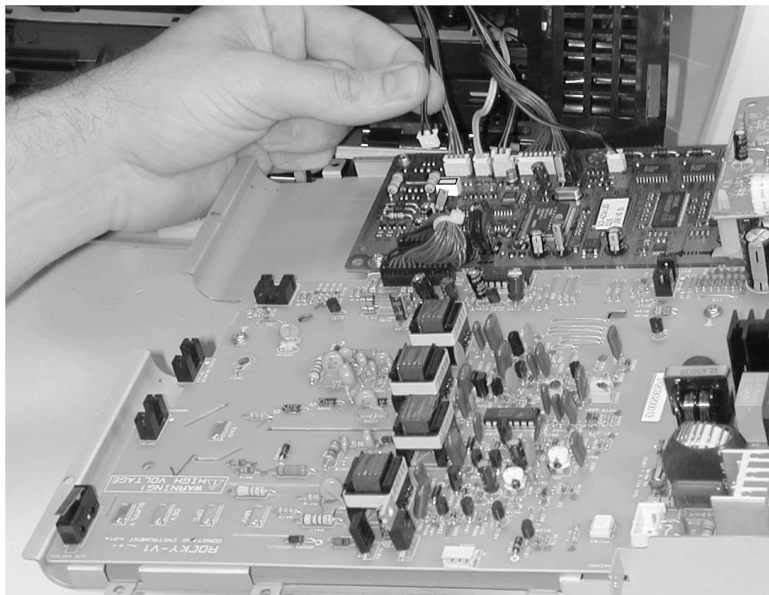

4038-001

Reinstallation note: Make note of the cable locations (A) for the cartridge fuse (CN4) and main paper feed cable (CN6) as these pin connectors can be interchanged. This reversal could cause the printer to malfunction.

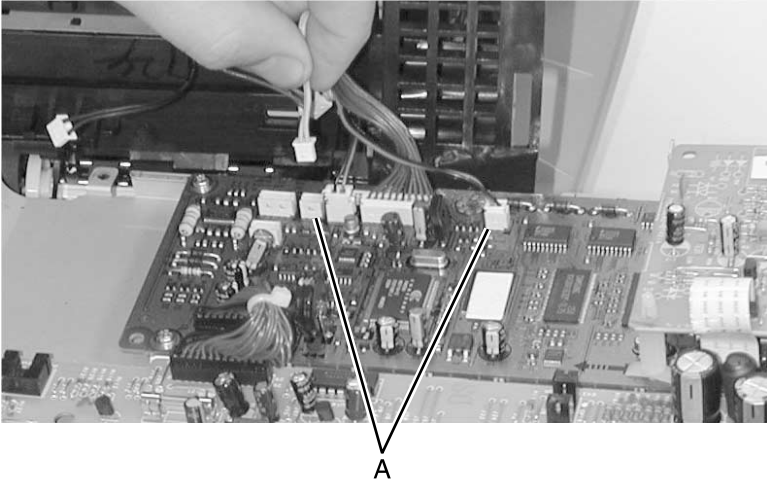

Fan removal

1. Remove the right side cover. See **“Right side”** on page 4-15 for more information.
2. Disconnect the fan cable from the LVPS/HVPS.



3. Pull the fan straight out to remove.



Fuser removal

1. Remove the card cage. See **“Card cage removal”** on **page 4-25** for more information.
2. Remove four screws (A).

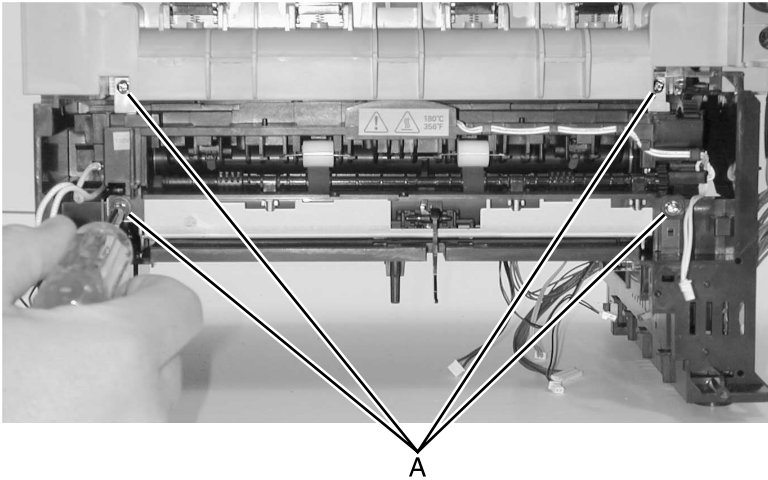

3. Pull the fuser straight out to remove.

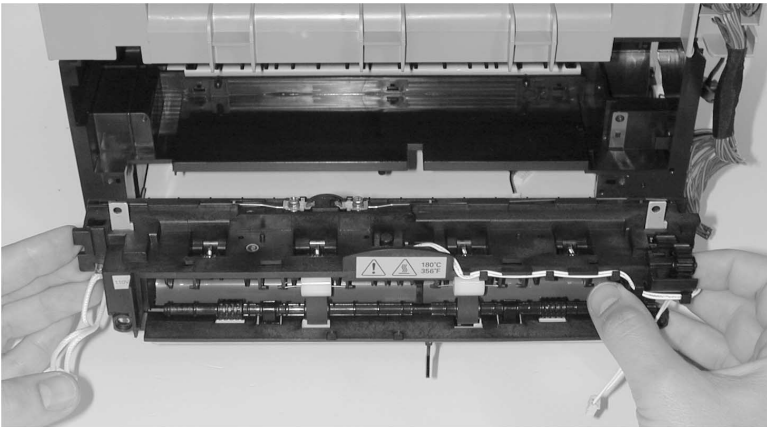

HVPS contact removal

1. Remove the right side cover. See **“Right side”** on page 4-15 for more information.
2. Remove the screw in the cover to the HVPS contacts.

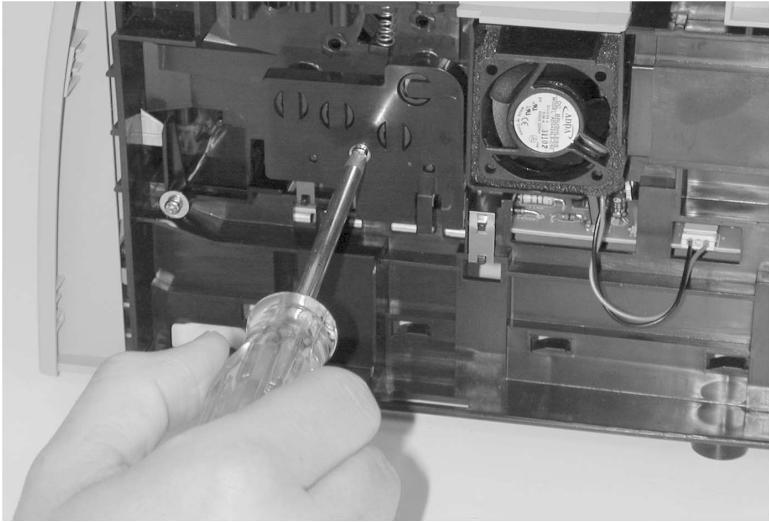

3. Remove the cover.
4. Using needle nose pliers, remove the HVPS contact(s).

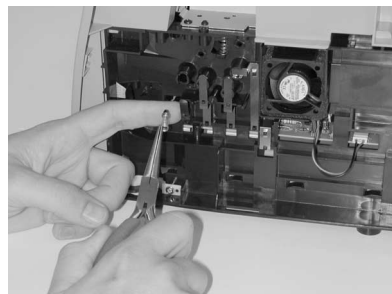
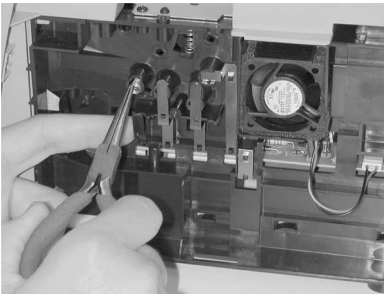



LVPS / HVPS card removal

1. Remove the card cage. See **“Card cage removal”** on **page 4-25** for more information.
2. Disconnect the cable (CN2) on the LVPS/HVPS card.

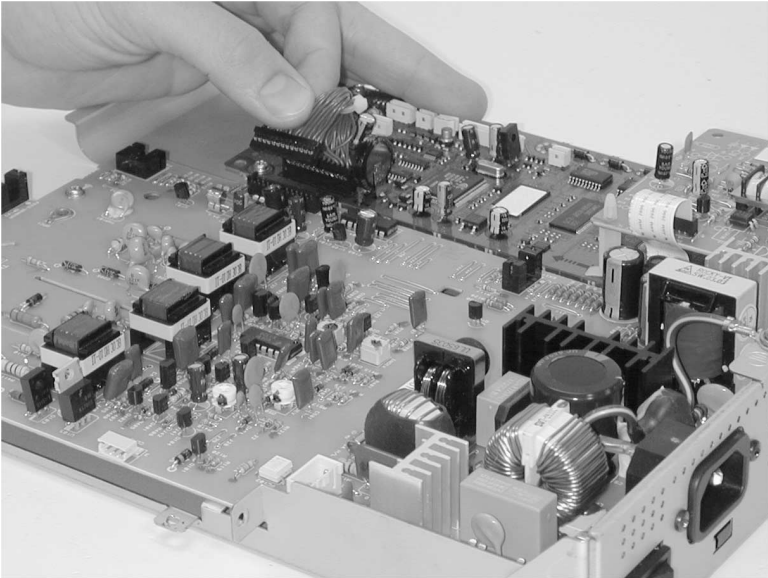

3. Remove seven screws (A).

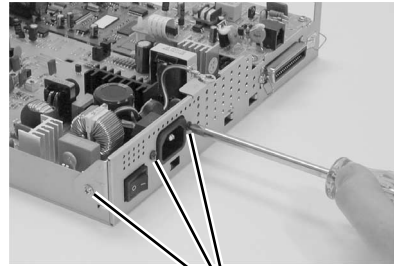
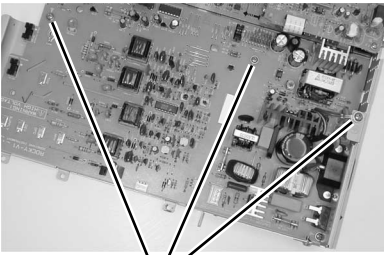

Note: The bracket securing the LVPS/HVPS card must be removed to reveal the last screw holding the LVPS/HVPS card.

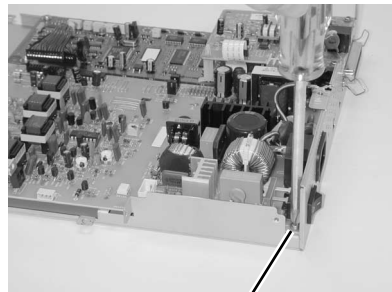
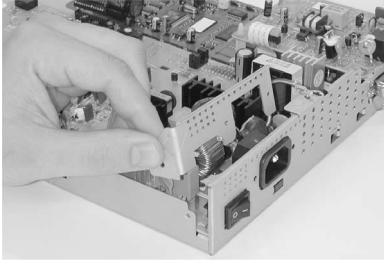

4038-001

4. Remove the LVPS/HVPS card.

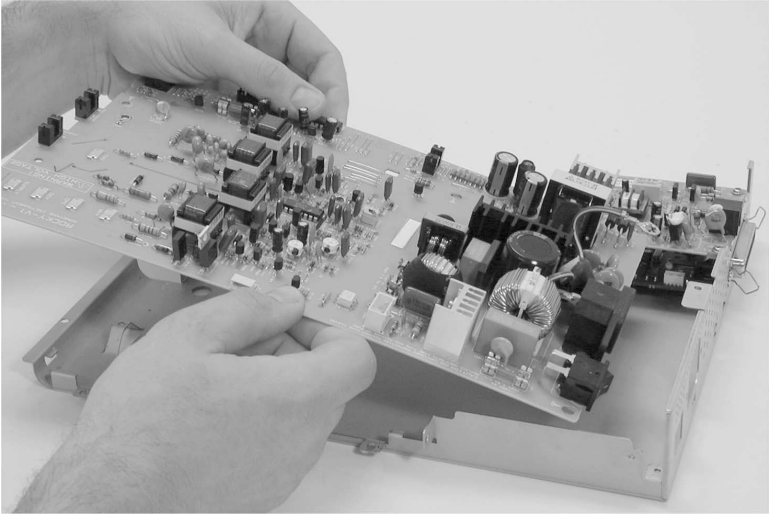

Main drive assembly removal

1. With the left side cover removed. See **“Left side” on page 4-12** for more information.
2. Remove six screws (A) across the top and bottom of the main drive assembly.

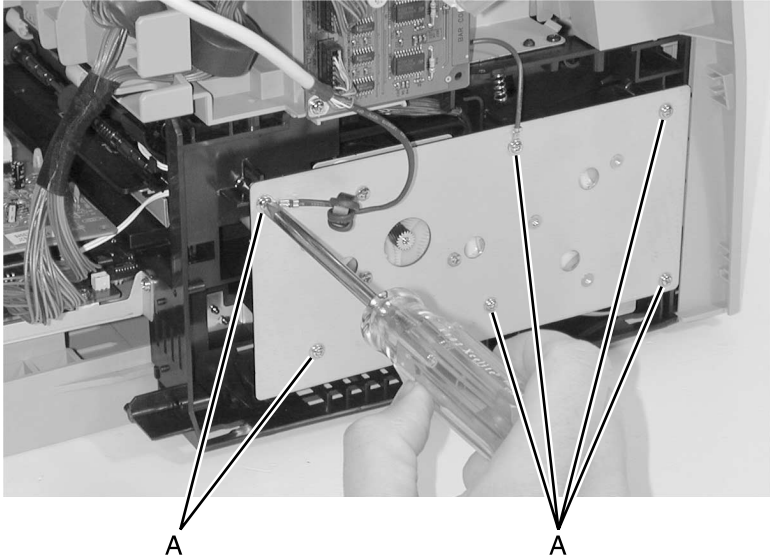

4038-001

3. Pull the main drive assembly out a little and disconnect the drive motor cable (A).



A

4. Lift out the main drive assembly to remove.

Main paper feed roller removal

1. Remove the middle cover and main drive assemblies. See **“Middle cover removal”** on page 4-3 and **“Main drive assembly removal”** on page 4-37 for information.
2. Remove the three screws (A) and the gear plate.

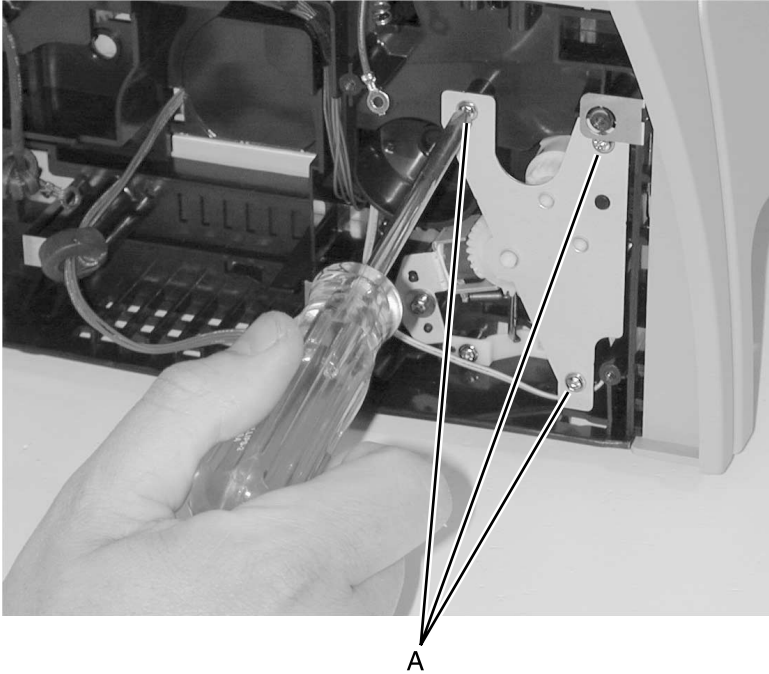

3. Remove the four gears.

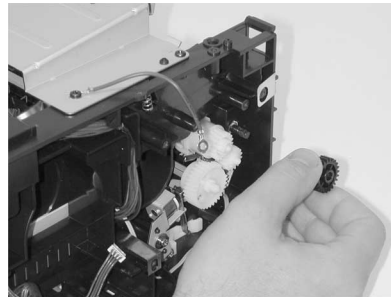
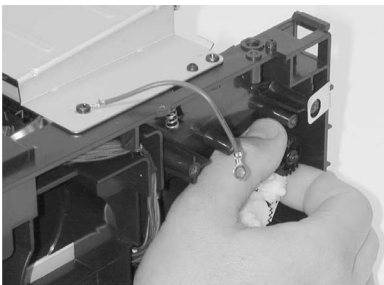

4. Remove the two screws (A).



A

5. Lift the metal plate and remove.

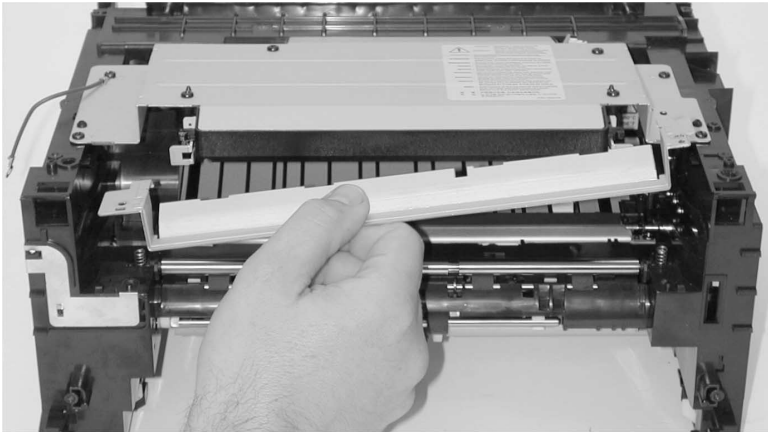

6. Lift the metal shaft (registration roller) with both bearings attached.

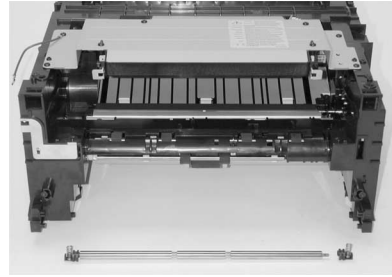
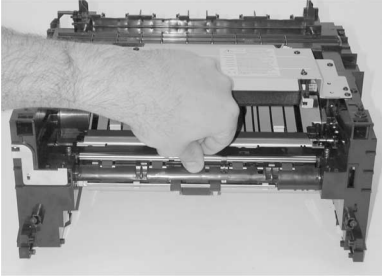

Reinstallation note: When installing the four gears, make sure the arms of the solenoids are in the correct position.

7. Pry up the main paper feed roller and remove.

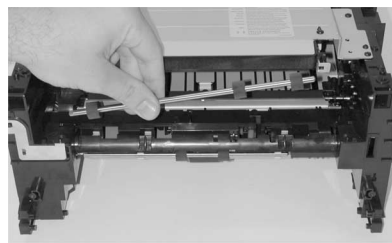
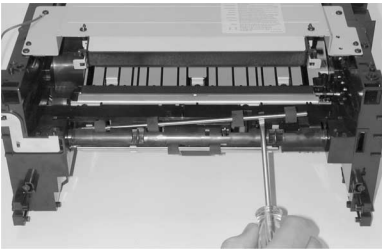

Main feed roller solenoid removal

1. With the card cage and main drive assembly removed. See **“Card cage removal” on page 4-25** and **“Main drive assembly removal” on page 4-37** for more information.
2. Remove the gear plate (A).

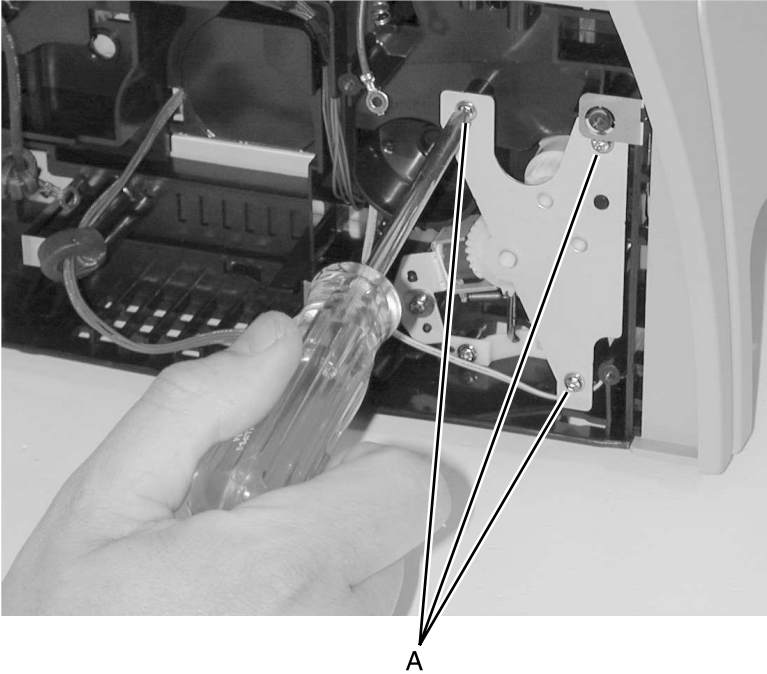

3. Remove the pick roller gear.

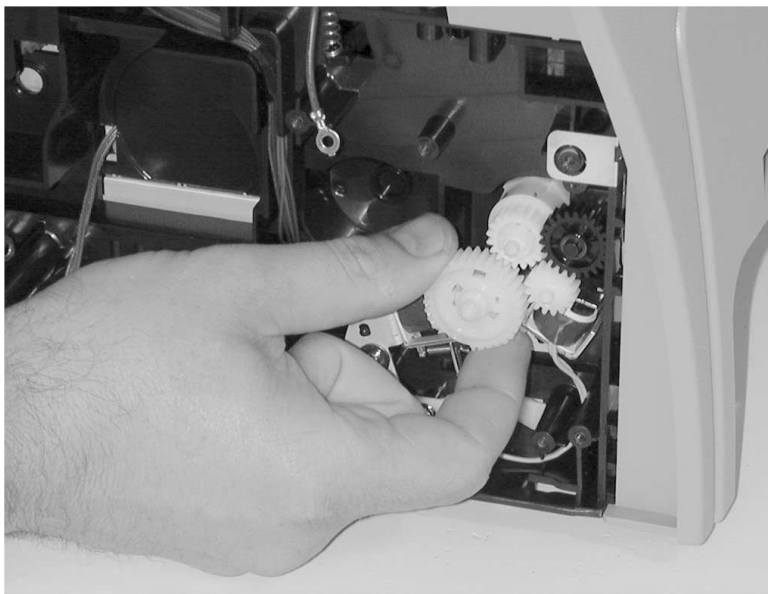

4. Remove one screw.



5. Remove the main feed roller solenoid.

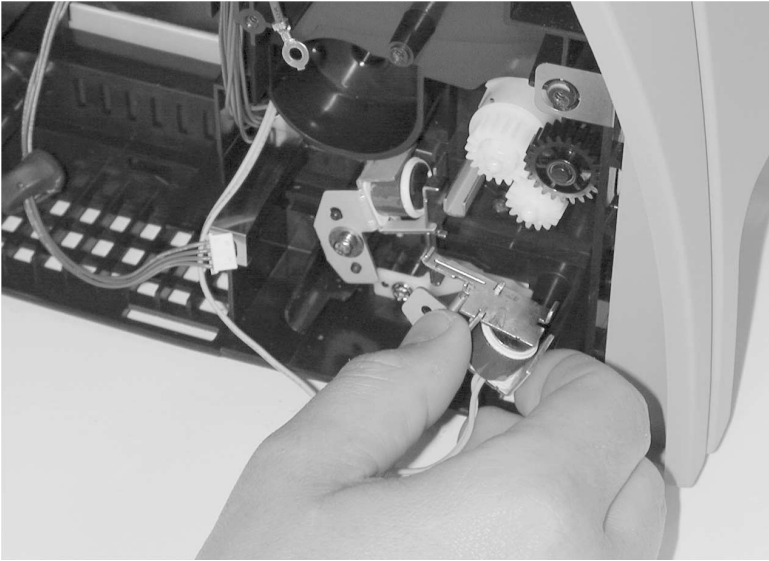

Manual paper feed sensor actuator removal

1. With the paper tray feed roller removed. See **“Paper tray feed roller removal”** on page 4-56 for more information.
2. Flex the tab with your thumb and pry up the end of the actuator.

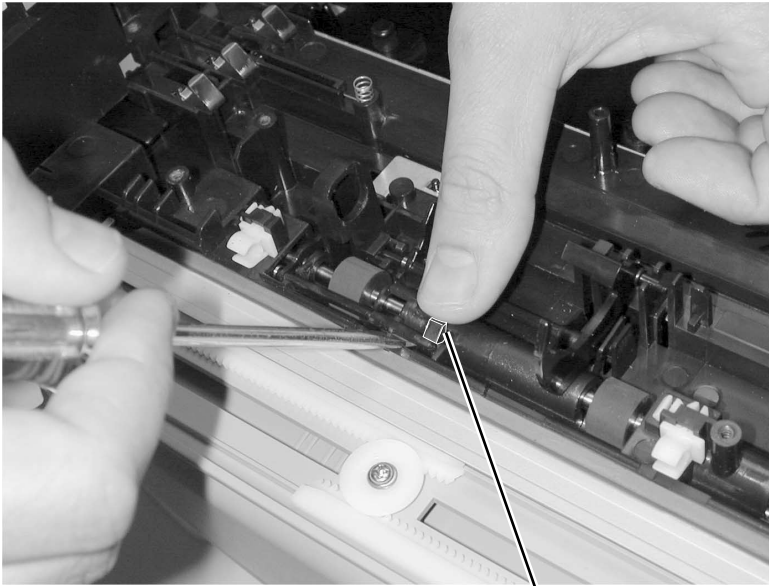

A

3. Lift and remove from the printer.

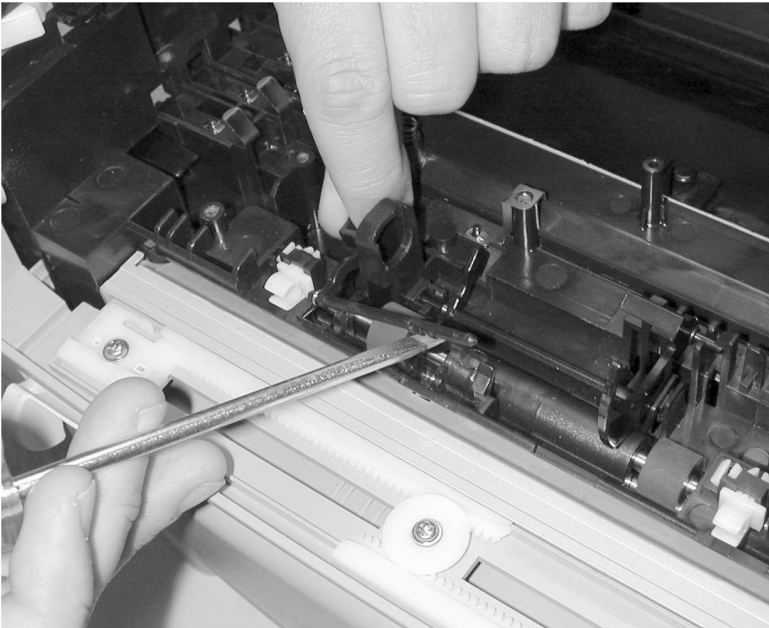

Note: Ensure the spring remains on the actuator.

Reinstallation note: Verify the spring is in the correct orientation and flexes the actuator.



Modem card removal

1. With the card cage removed. See **“Card cage removal”** on **page 4-25** for more information.
2. Disconnect the modem ribbon cable (CN3).

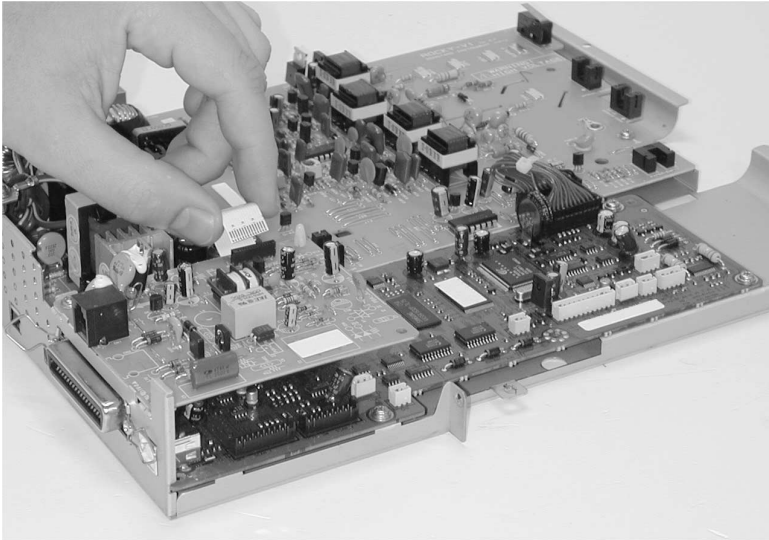

3. Remove two screws (A).

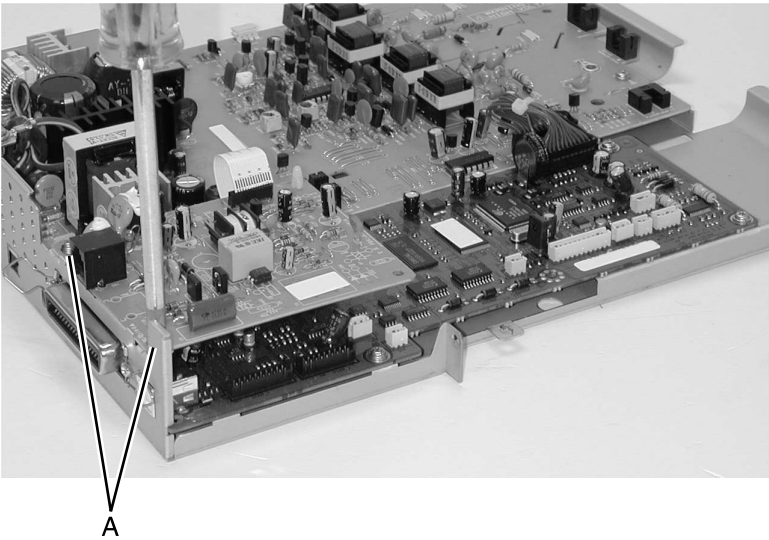

4. Using needle nose pliers, squeeze the standoff to release the modem card.

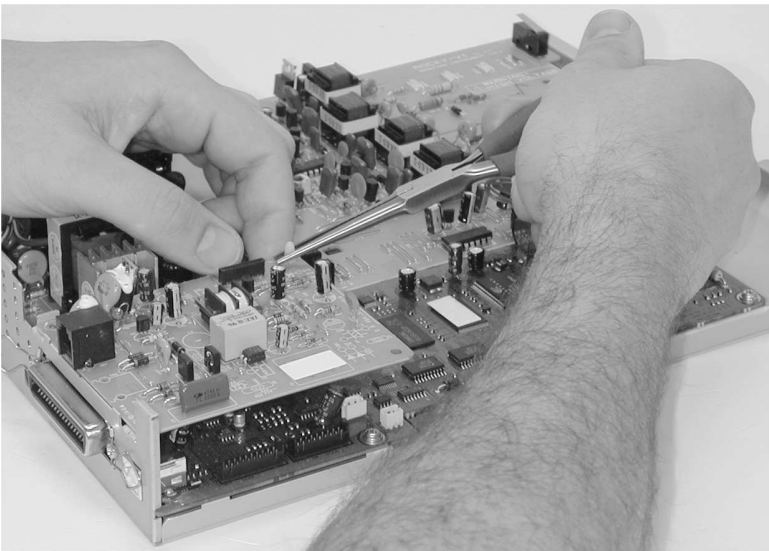

5. Remove the modem card.

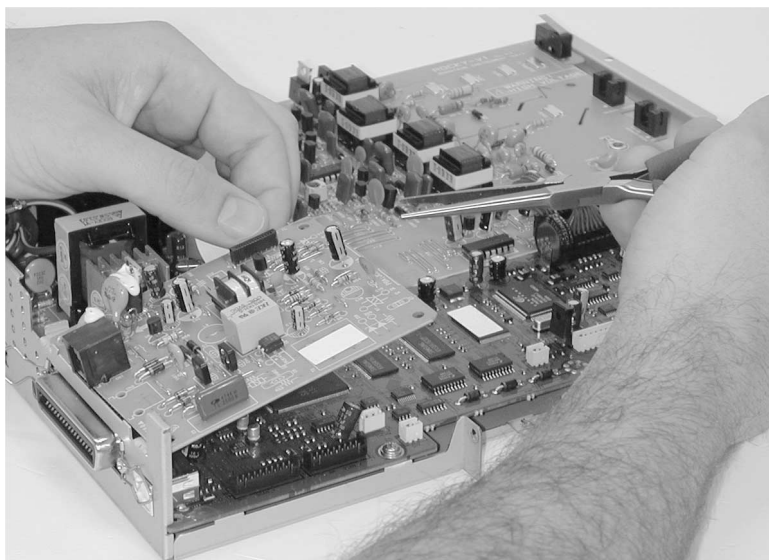

Operator panel removal

1. Remove three screws (A) on the underside of the operator panel.



A

2. Rotate the top portion of the operator panel up.



3. Disconnect the operator panel cables (CN1 and CN2).



4. Remove the operator panel.

Paper empty sensor actuator removal

1. Remove the card cage. See **“Card cage removal”** on **page 4-25** for more information.
2. Deflect the tab to the side of the actuator to release.

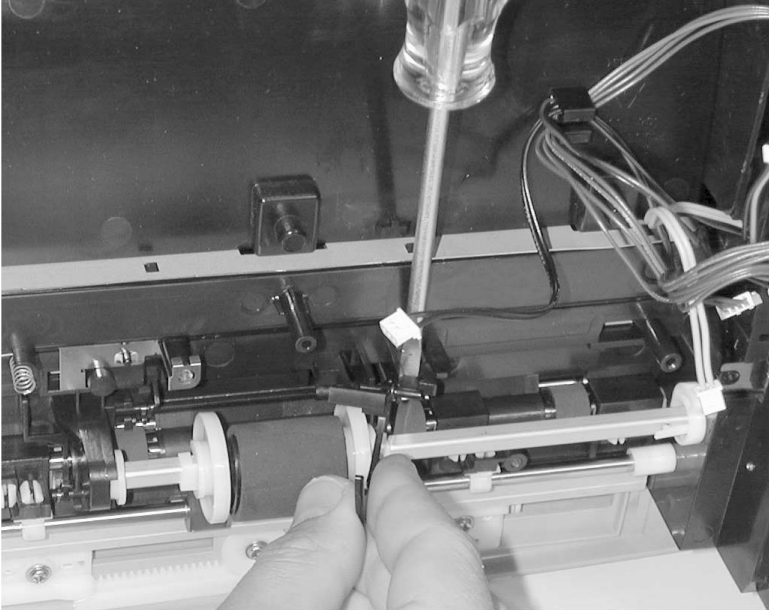

3. Remove the paper empty sensor actuator.

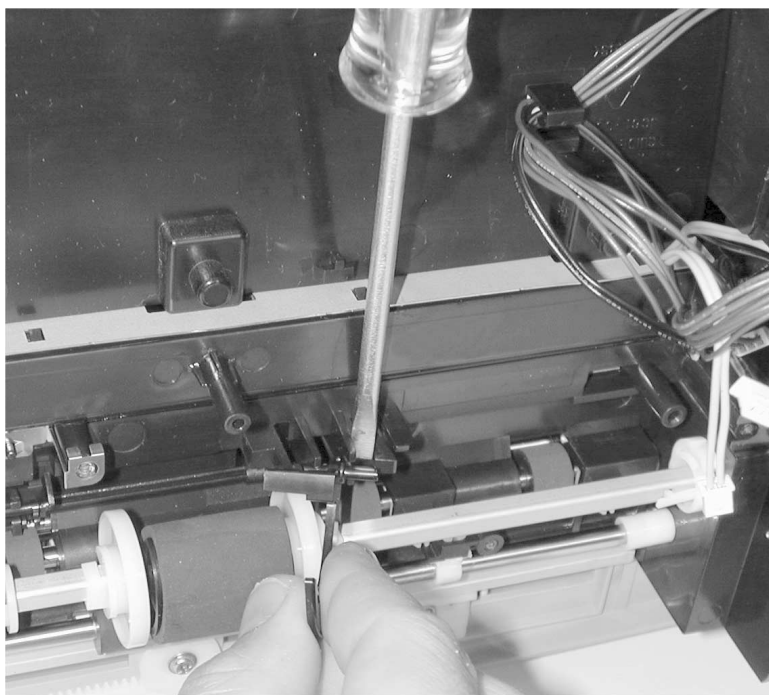

Paper feed sensor actuator removal

1. Remove the paper tray pick roller assembly and paper empty sensor actuator. See **“Paper tray pick roller assembly removal” on page 4-57** and **“Paper empty sensor actuator removal” on page 4-52** for more information.
2. Deflect the right side of the actuator to release.

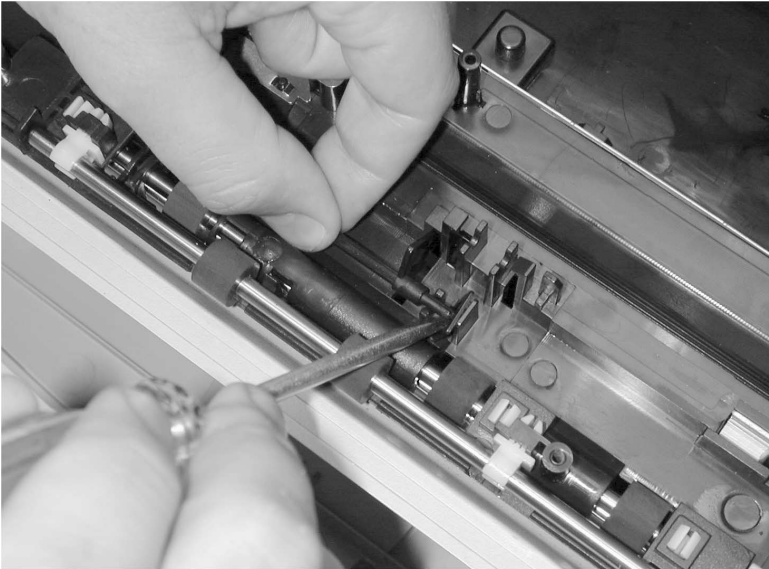

3. Lift and remove the paper feed sensor actuator.

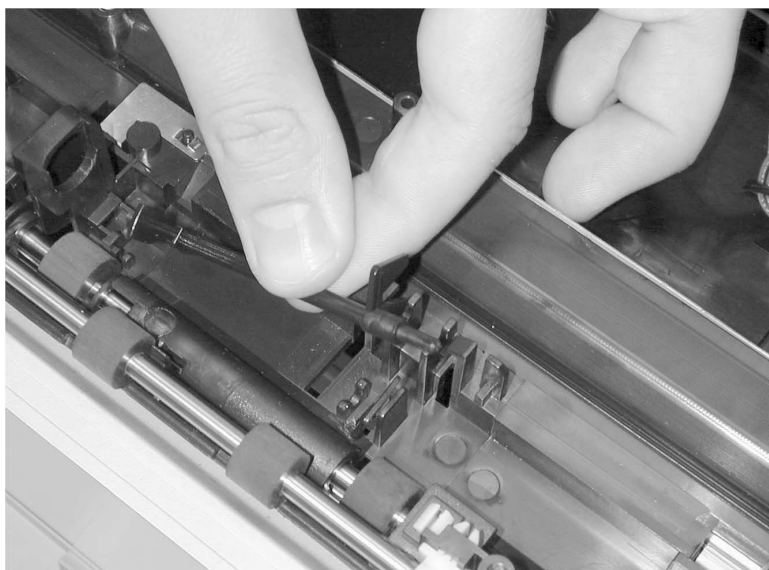

Paper tray feed roller removal

1. Remove the paper tray pick roller. See **“Paper tray pick roller assembly removal”** on page 4-57 for more information.
2. Pull down to release from bushings (A).

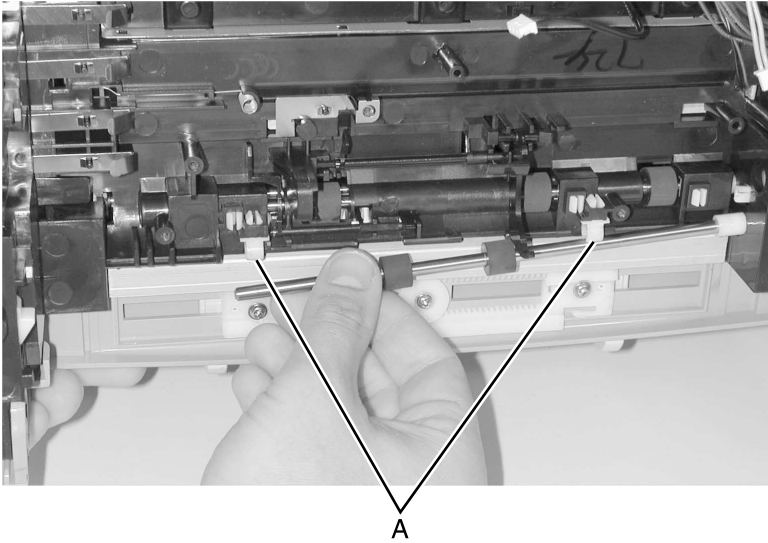

3. Remove the paper tray feed roller.

Paper tray pick roller assembly removal

1. Remove the main drive assembly. See **“Main drive assembly removal”** on page 4-37 for more information.
2. Remove the paper tray.
3. Remove the three screws (A) securing the gear plate and remove the plate.

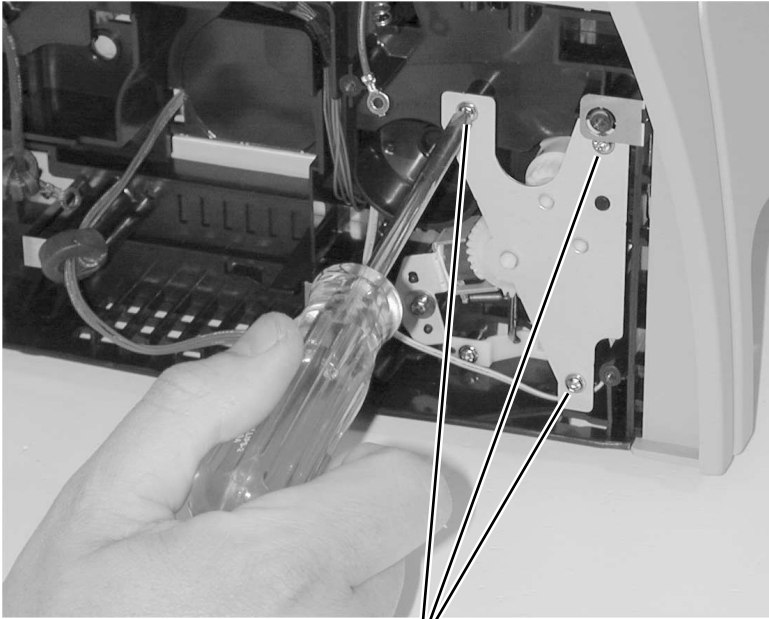

A

4. Remove the pick roller gear.

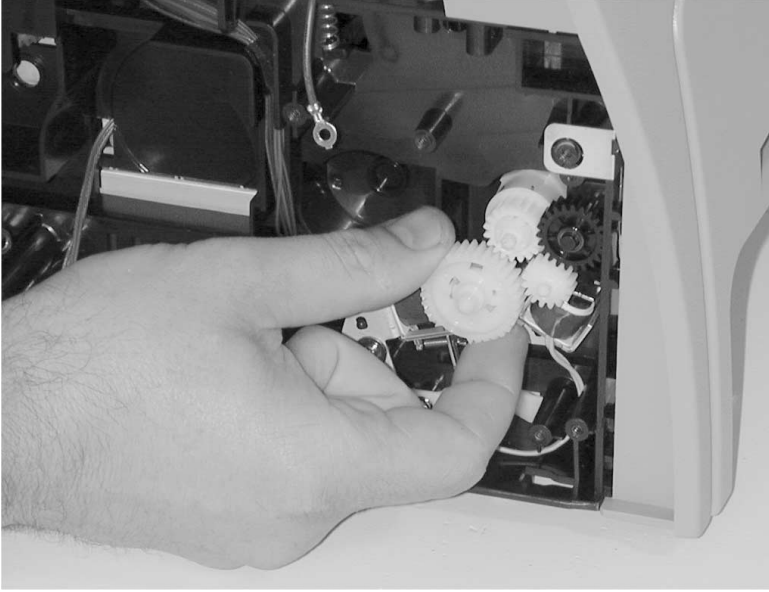

5. With the card cage removed. See **“Card cage removal”** on **page 4-25** for more information.

6. With a flat blade screwdriver, lift the tab (A) on the right bushing.

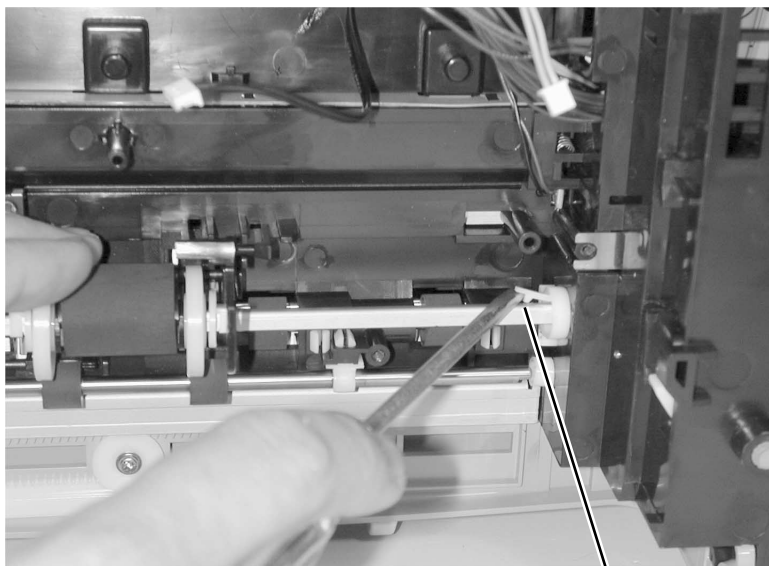

A

7. While holding the tab up, push the pick roller to the right until the shaft (A) is released on the left side.

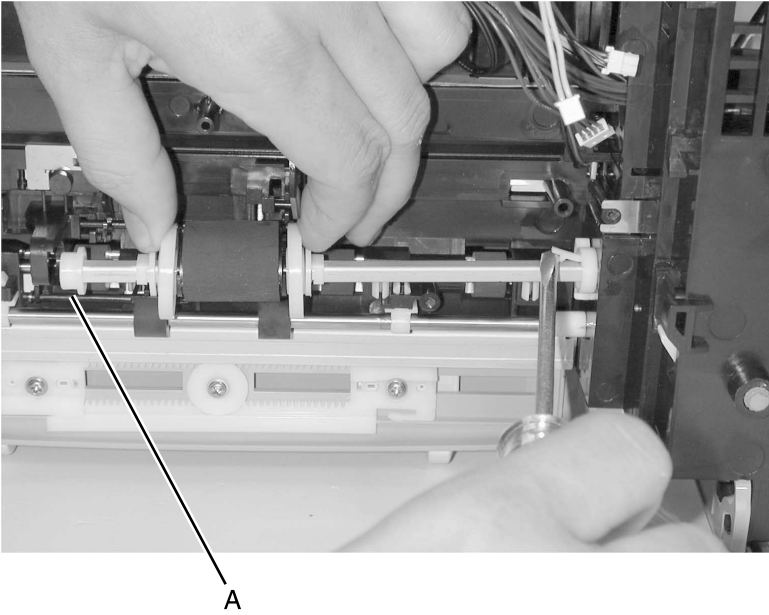

8. Remove the pick roller.

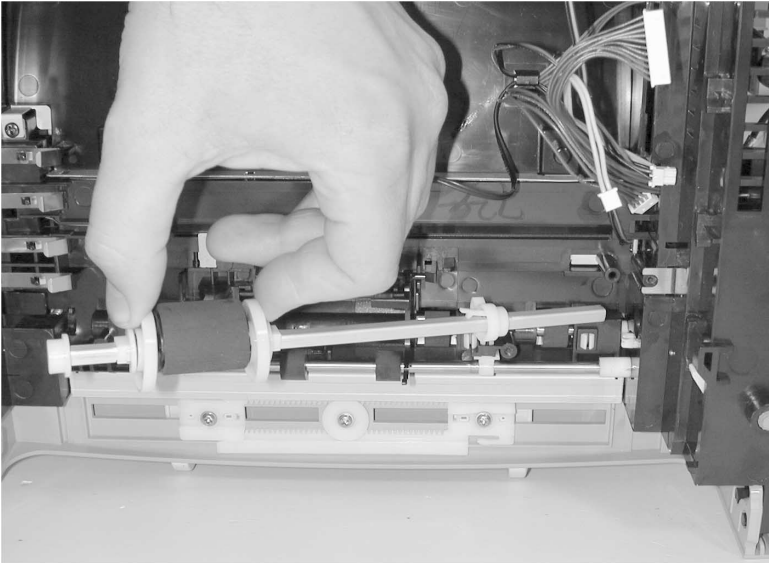

Paper tray solenoid removal

1. Remove the card cage and main drive assembly. See **“Card cage removal”** on page 4-25 and **“Main drive assembly removal”** on page 4-37 for more information.
2. Remove the screw from the solenoid.

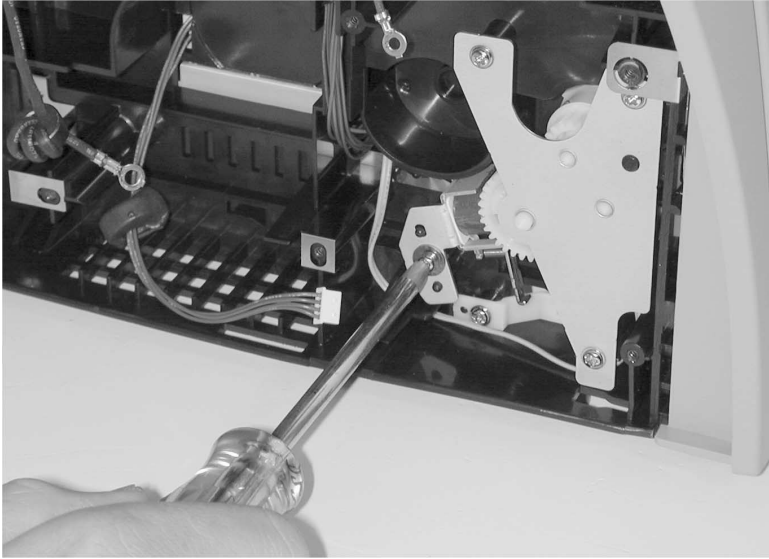

4038-001

3. Remove the paper tray solenoid.

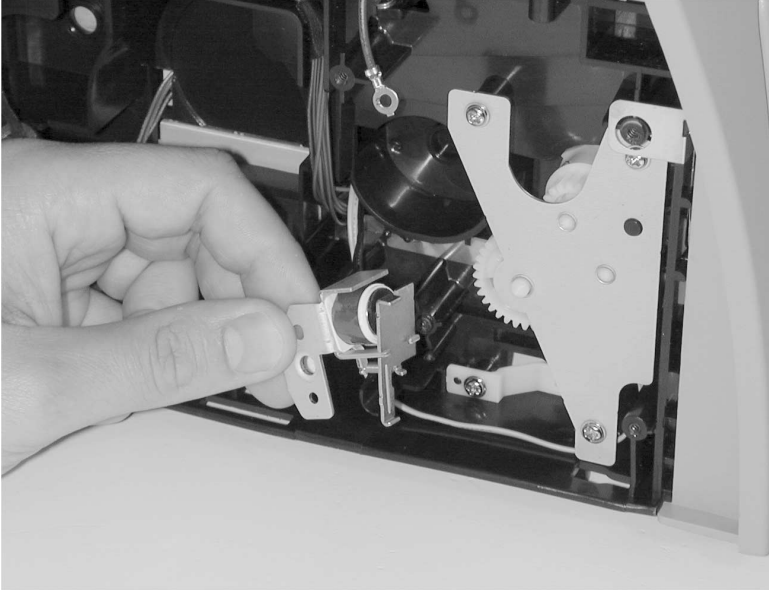

Printhead removal

1. Remove the middle cover. See **“Middle cover removal”** on **page 4-3** for more information.
2. Remove four screws (A) from the printhead.

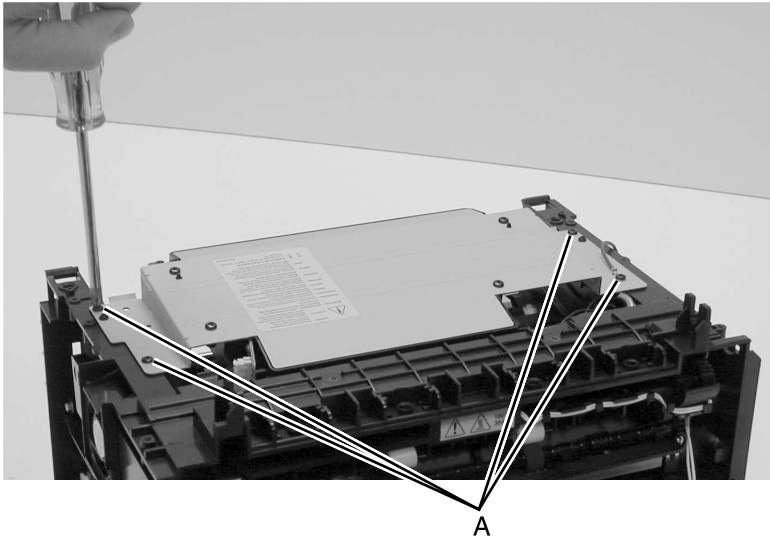

3. Lift the printhead.
4. Disconnect two connectors.

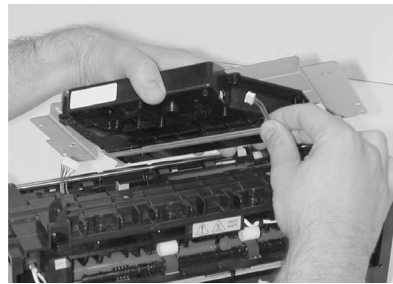

5. Remove the printhead.

Scanner assembly removal

1. Remove the left, right and rear covers. See **“Left side” on page 4-12**, **“Right side” on page 4-15**, and **“Rear cover removal” on page 4-5** for more information.
2. Remove the ground screw from the main drive assembly.

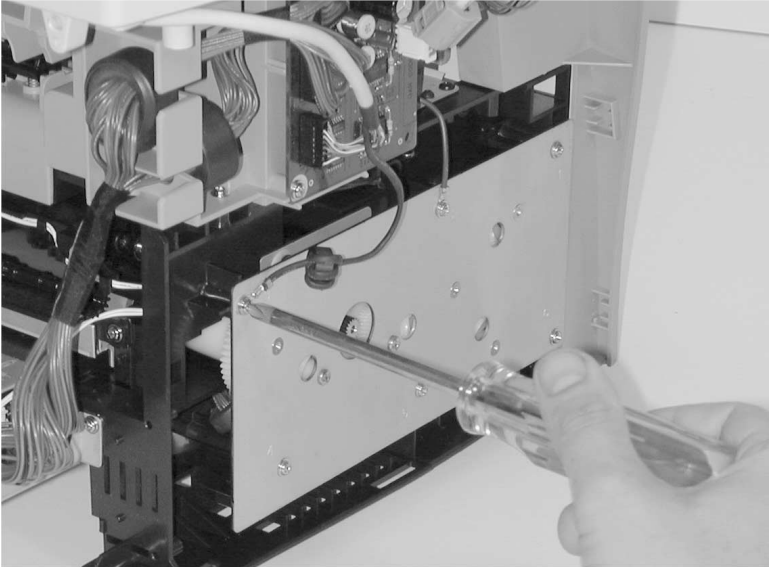

3. Disconnect the following cables from the scanner card:

- cable (A) (CN3)

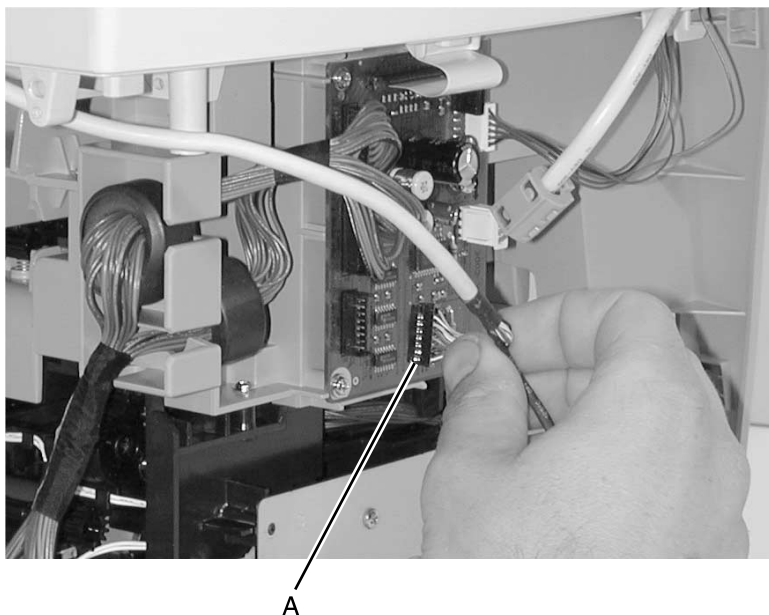

- cable (A) with toroid (CN6)

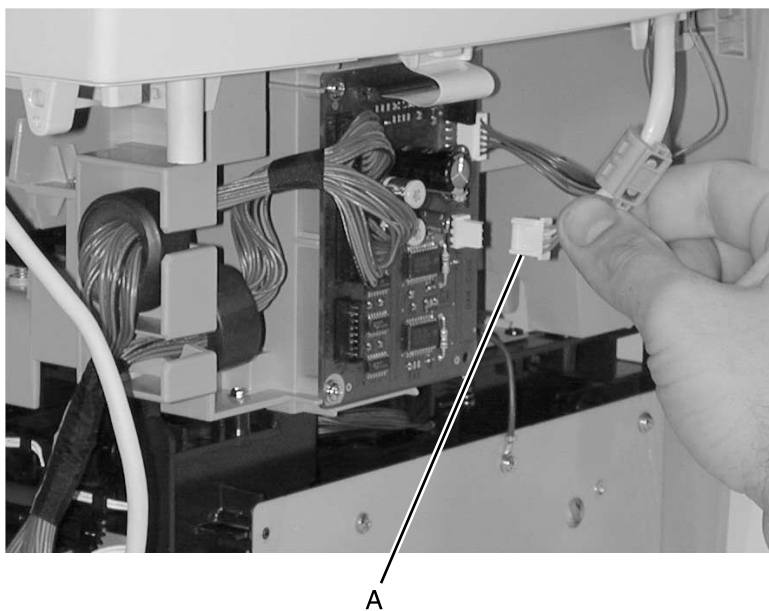

4038-001

- cable (A) (CN2)

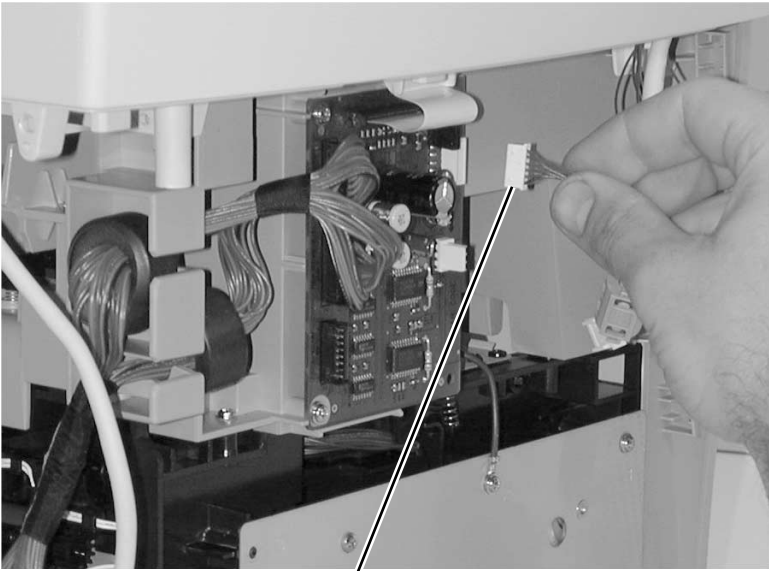

A

- ribbon cable (A) (CN1)



A

4. Remove two screws in rear of printer.

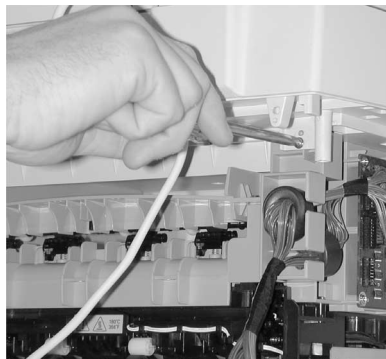
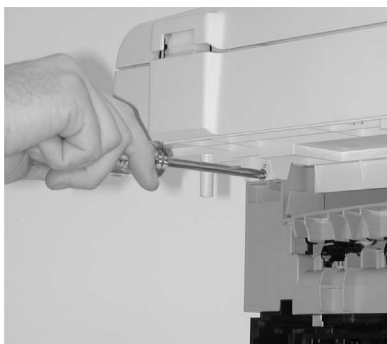

5. Remove the scanner assembly.

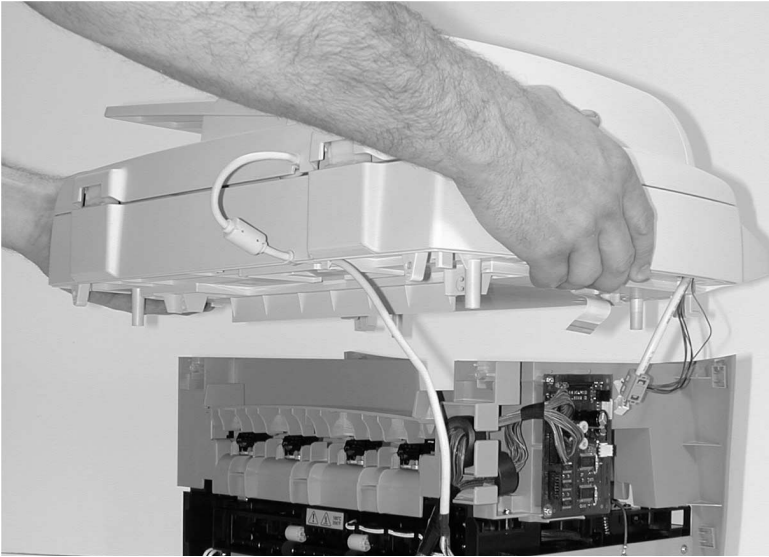

Scanner card assembly removal

1. Remove the left side cover. See **“Left side”** on page 4-12 for more information.
2. Disconnect all cables from the scanner card.

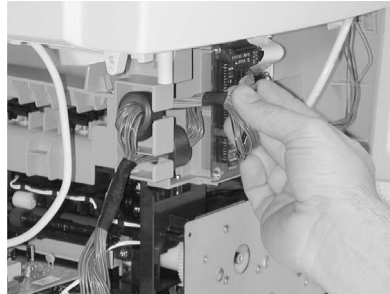
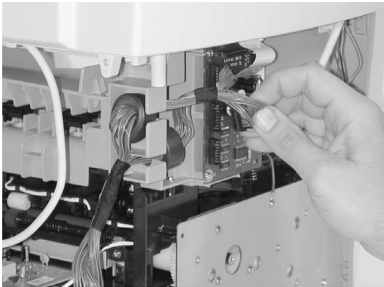

3. Remove two screws (A) from the card.



A

4. Lift out the scanner card to remove.

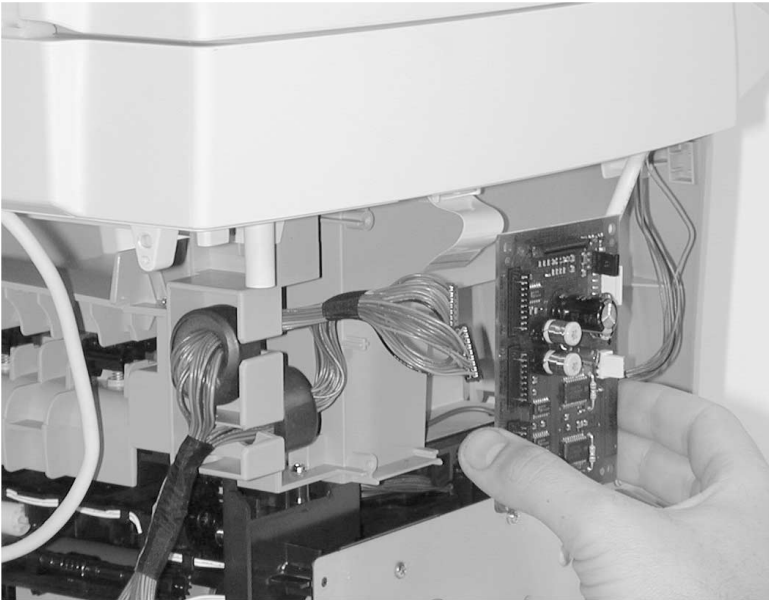

Scanner assembly cushion removal

Pull the scanner cushion away to release from adhesive.

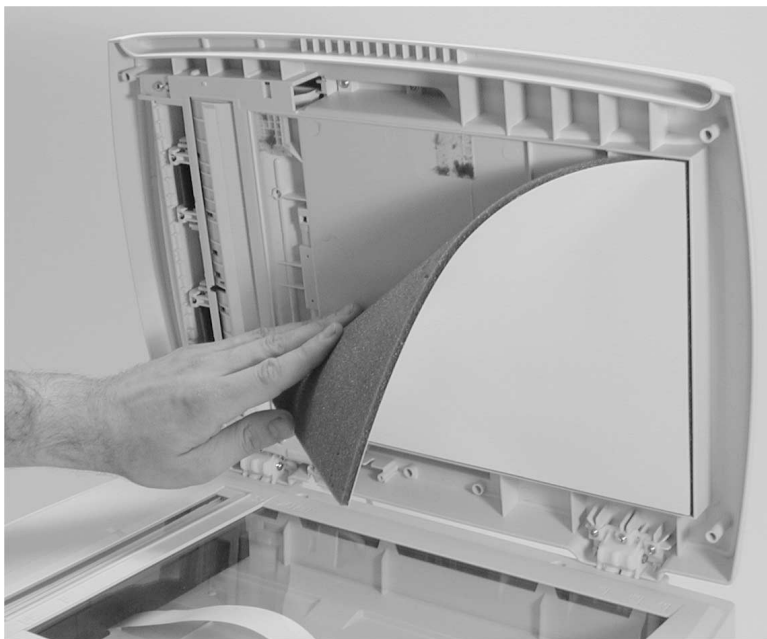

Scanner assembly hinge removal

1. With the scanner document cover removed. See **“Scanner assembly document cover removal”** on page 4-7 for more information.
2. Lay the scanner document cover upside down.
3. Remove three screws (A) from the hinge.



4. Tilt back through catches and lift out.

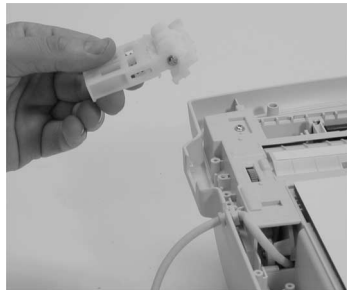



System board removal

1. Remove the modem card. See **“Modem card removal”** on **page 4-47** for more information.
2. Disconnect the LVPS/HVPS cable (CN14).

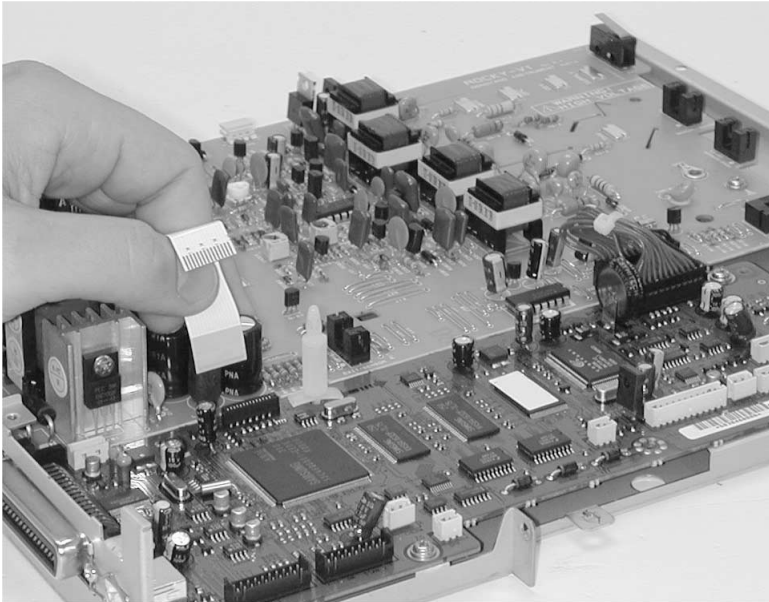

3. Remove the modem card ribbon cable (CN1).

Note: See reinstallation note.

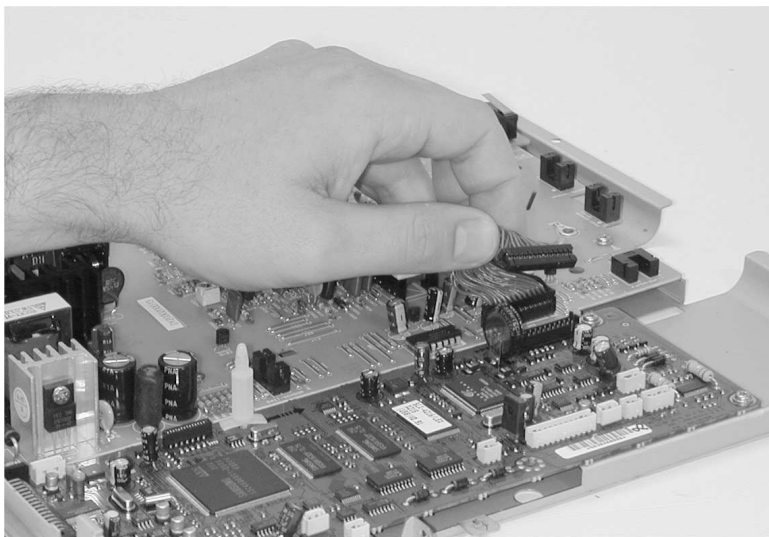

4. Remove five screws (A).

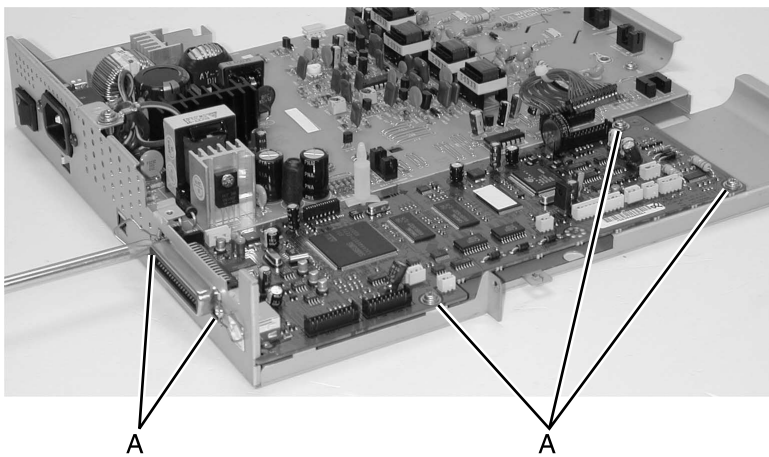

5. Remove the system board.



6. Remove the modem card standoff from the system board.

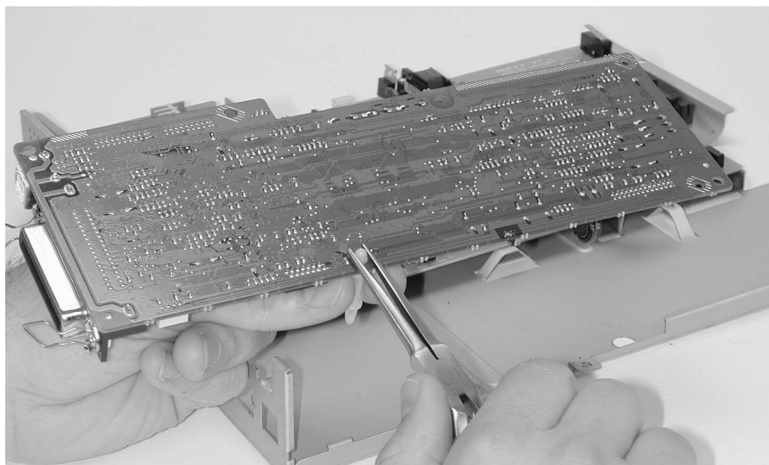

Reinstallation note: Reinstall the modem card standoff and ribbon cable on the new system board.

Transfer roll removal

1. Open the cartridge access cover.
2. Remove the toner cartridge.

Note: Place toner cartridge on a flat surface and cover with paper to prevent light getting to the developer. Prolonged exposure of light to the green PC drum can damage the cartridge.

3. Pry up the transfer roll (A) on the right end.

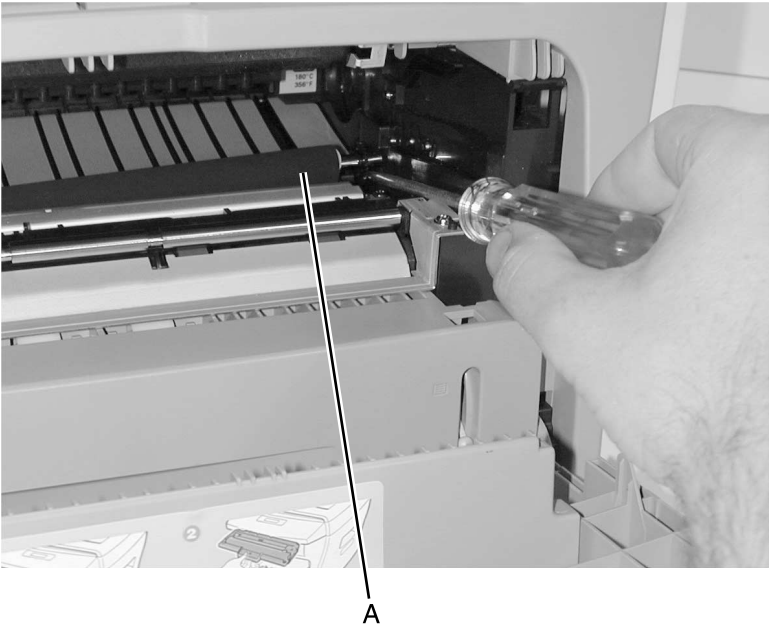

4. Using a pair of needle nose pliers, grab the right end of the shaft and move to the right.



Note: Touching the roller may cause print quality problems.

5. Once the left side of the transfer roll is released, still holding with pliers, remove from the printer.



4038-001

5. Locations

Front view

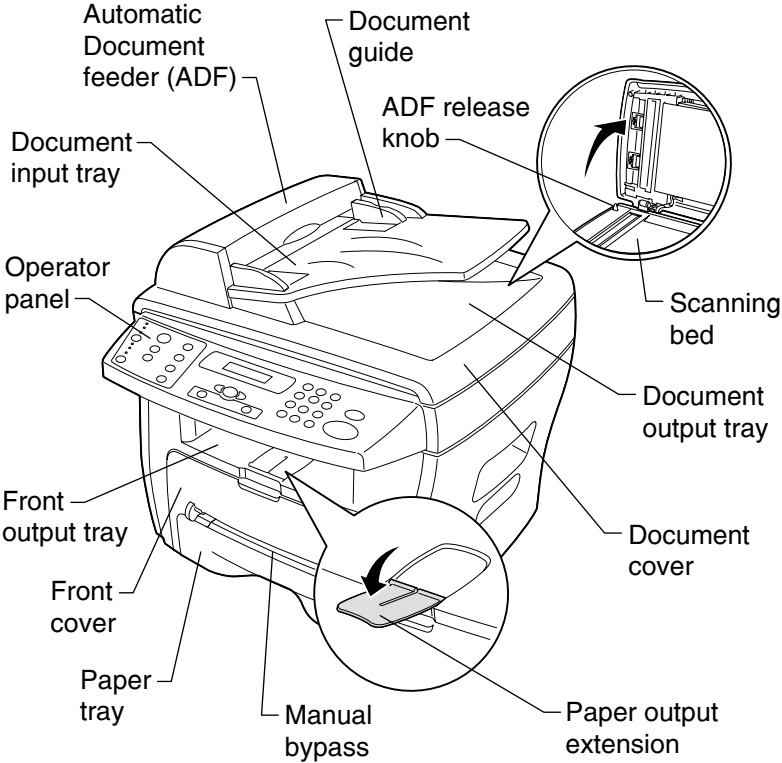

4038-001

Rear view

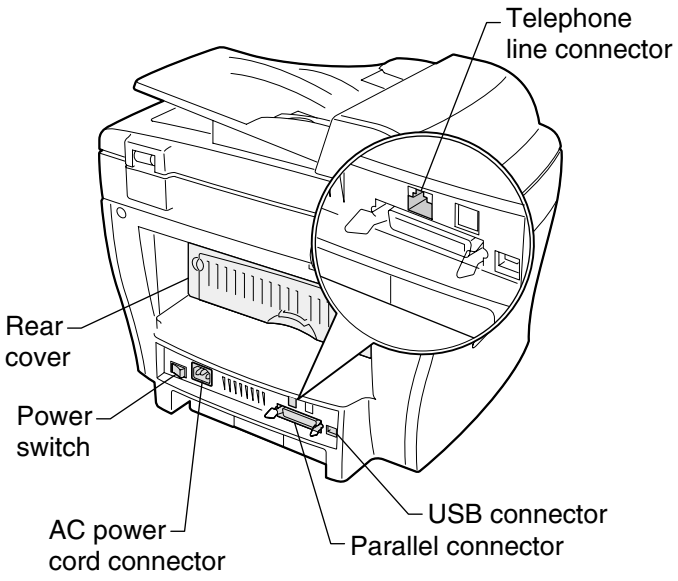

EP rollers

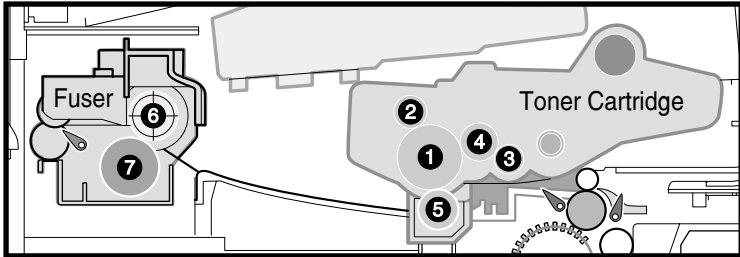

1	OPC drum
2	Charge roller
3	Supply roller
4	Developing roller
5	Transfer roller
6	Heat roller
7	Pressure roller

Operator panel

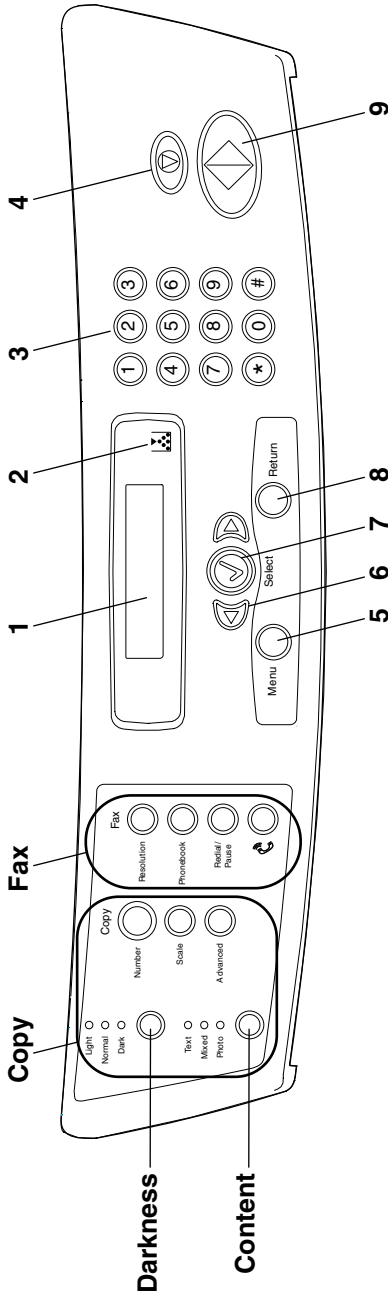

C o p y	Content	Selects the output type for the current copy job. Select from Text, Mixed, or Photo quality.
	Darkness	Adjusts the brightness of the current copy job to the selected value.
	Number	Selects the number of copies that you want to make.
	Scale	Adjusts the size of content on the page.
	Advanced	Accesses special copy features such as Collate, 2-Up, and 4-Up.
	Resolution	Adjusts the resolution of a faxed document.
F a x	Phonebook	Accesses and stores fax numbers as shortcuts and groups.
	Redial/Pause	Redials the most recently used fax number. Also used to enter programmed delays when entering shortcuts.
	Telephone icon	Starts a dial tone (used to send a fax manually).
1 2 3 4 5 6 7 8 9	Display	Displays the current status and prompts during an operation.
	Toner Low indicator	Turns on when the toner cartridge is near empty.
	Numeric keypad	Used to enter a menu number, to dial a fax number, or to enter alphanumeric characters.
	Stop/Clear	Stops an operation at any time.
	Menu	Enters menu functions and scrolls through menu items.
	Scroll buttons	Scrolls through the options available for the selected menu item.
	Select	Confirms the selection on the display.
	Return	Sends you back to the previous menu level or exits the menu.
	Start	Starts a job.

HVPS / LVPS card

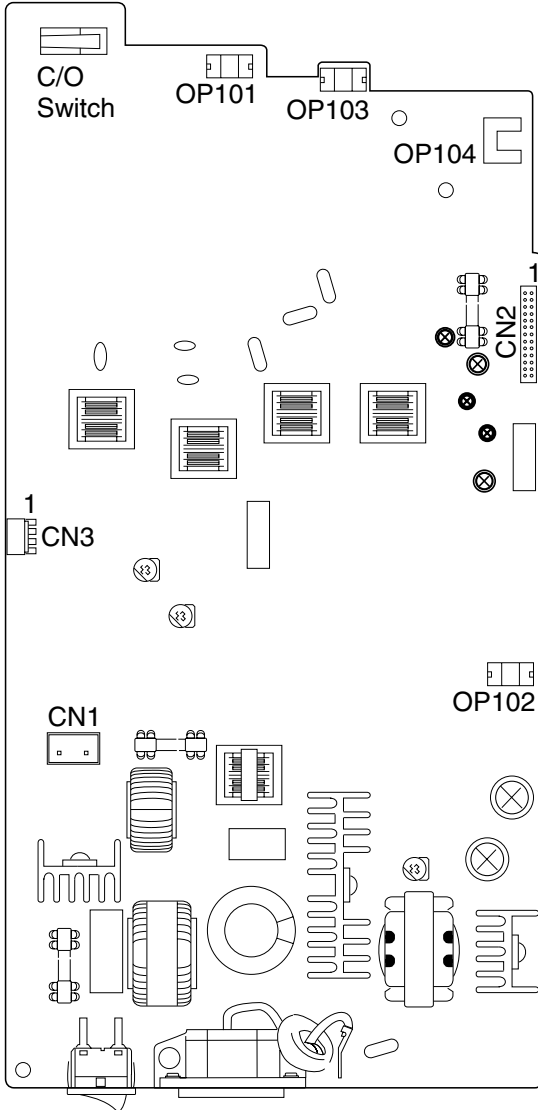

Function name	Name on card	# of pins	Pin #	Signal
Fuser	CN1	2	1 2	110 / 220 / 240 V ac Neutral
System board	CN2	26	3, 4 7 12 5,6,8,9,10, 11	+5 V dc +12 V dc +24 V dc Ground
Cooling fan	CN3	3	1	+24 V dc
Cover open switch	C/O Switch			
Manual bypass sensor	OP101			
Main paper feed / toner cartridge present sensor	OP103			
Fuser exit sensor	OP102			
Paper tray empty	OP104			

4038-001

Modem card

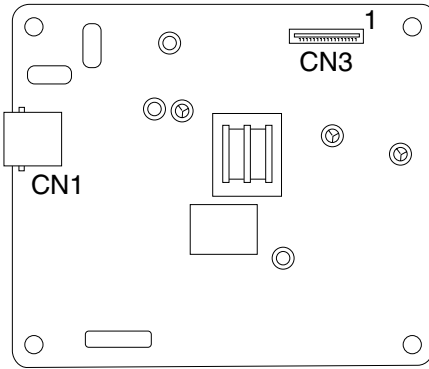

Function name	Name on card	# of pins	Pin #	Signal
System board	CN3	14	10 2, 12	+5 V dc Ground

Operator panel card

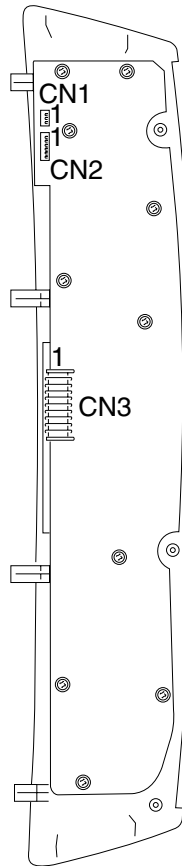

Function name	Name on card	# of pins	Pin #	Signal
Document cover sensor	CN1	3	1 3	+5 V dc Ground
Scanner card	CN2	6	2 1	+5 V dc Ground

Scanner card

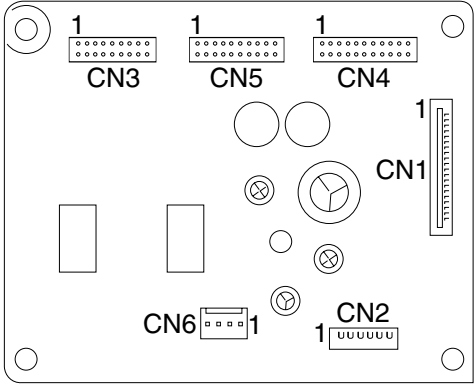

Function name	Name on card	# of pins	Pin #	Signal
CCD module	CN1	24	19 22 1,3,5,7,12, 20,24	+5 V dc +24 V dc Ground
Operator panel	CN2	6	2 1	+5 V dc Ground
ADF	CN3	16	3 2,4 1,11,13,15	+5 V dc +24 V dc Ground
System board	CN4	26	1,2,3 8,9,10,18, 19,20,22, 24,26	+5 V dc Ground
System board	CN5	26	1,2,3,4,5 8,9,10,18, 19,20,22, 24,26	+24 V dc Ground
CCD module motor	CN6	4		

System board

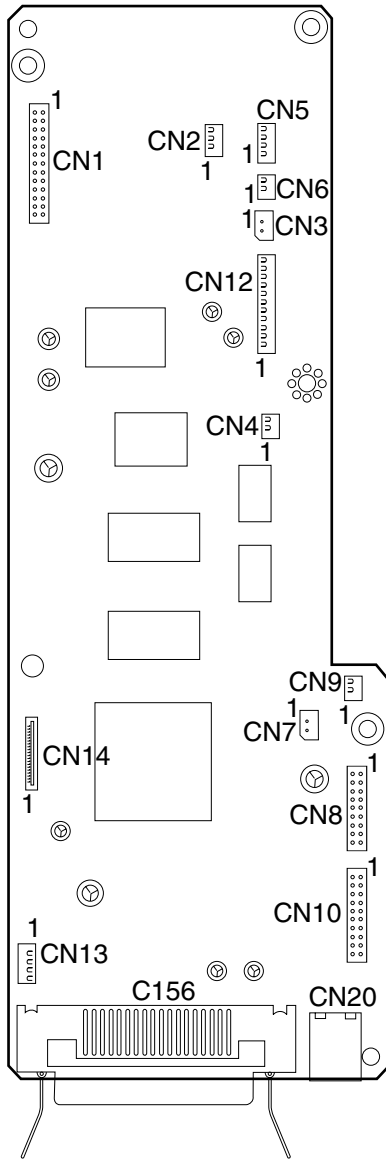

Function name	Name on card	# of pins	Pin #	Signal
HVPS/LVPS	CN1	26	3,4 7 12 5,6,8,9,10, 11	+5 V dc +12 V dc +24 V dc Ground
Paper tray solenoid	CN2	3	3	+24 V dc
Pre-transfer LED	CN3	2	1	+3.3 V dc
Toner cartridge fuse	CN4	2		
Main drive motor	CN5	4		
Main paper feed / bypass solenoid	CN6	2	1	+24 V dc
Fuser thermistor	CN7	2		
Scanner card	CN8	26	1,2,3,4,5 10,15,16, 17,18,20, 21,22,24,26	+24 V dc Ground
Speaker	CN9	2		
Scanner card	CN10	26	1,2,3, 8,9,10,18, 19,20,22, 24,26	+5 V dc Ground
Printhead	CN12	11	5 7 4,8,9,11	+24 V dc +5 V dc Ground
Not used	CN13			
Modem card	CN14	14	10 2,12	+5 V dc Ground

ADF paper path

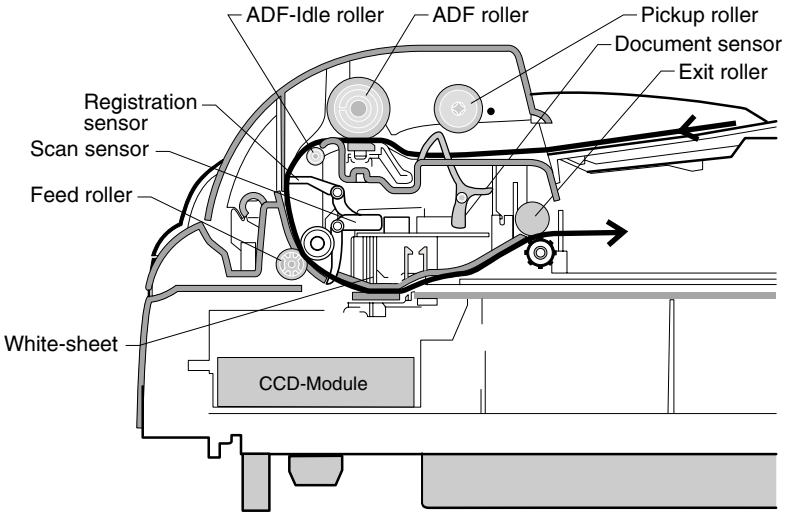

Printer engine paper path/paper jams

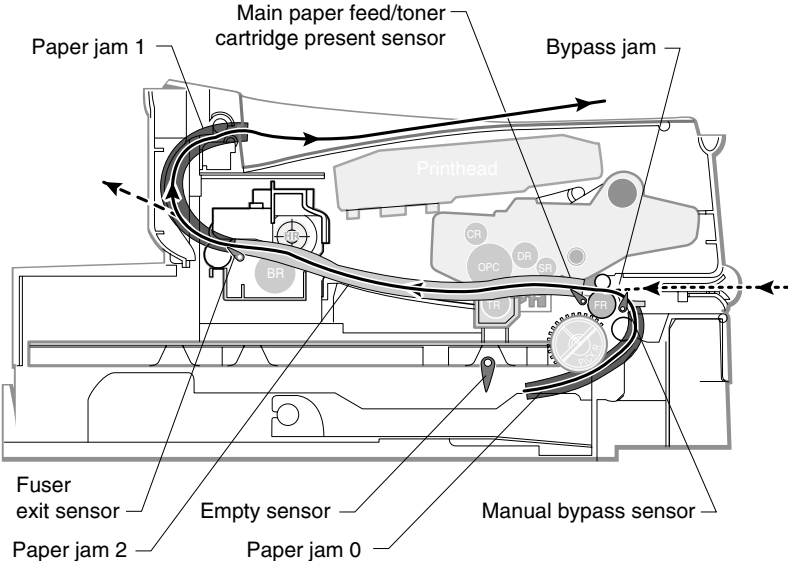

4038-001

6. Preventive maintenance

The Lexmark X215 MFP does not require preventive maintenance.

4038-001

7. Parts catalog

How to use this parts catalog

- **SIMILAR ASSEMBLIES:** If two assemblies contain a majority of identical parts, they are shown on the same list. Common parts are shown by one index number. Parts peculiar to one or the other of the assemblies are listed separately and identified by description.
- **NS:** (Not Shown) in the Asm-Index column indicates that the part is procurable but is not pictured in the illustration.
- **PP:** (Parts Packet) in the Description column indicates the part is contained in a parts packet.

Assembly 1: Scanner assembly

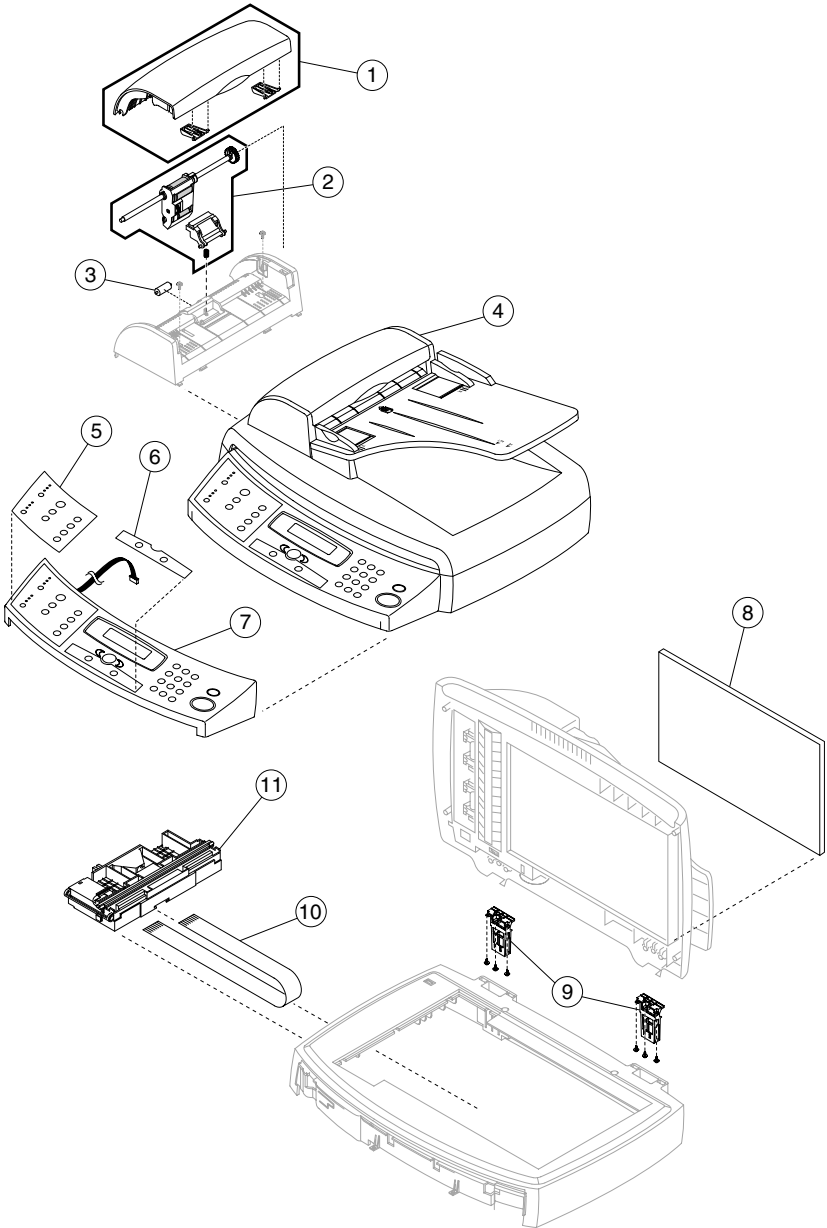

Assembly 1: Scanner assembly

Index	P/N	Units	Description
1—1	56P1931	1	Cover asm, ADF access
2	56P1923	1	Kit asm, ADF pick roll/pad
3	56P1922	1	Roller, ADF idler
4	56P1983	1	Scanner, complete
5	56P1936	1	Overlay, main
6	56P1935	1	Overlay, menu/select/return
7	56P1934	1	Panel asm, operator
8	56P1932	1	Cushion, document cover
9	56P1933	2	Hinge, document cover
10	56P1941	1	Cable, CCD
11	56P1940	1	Module asm, CCD

Assembly 2: Main assembly

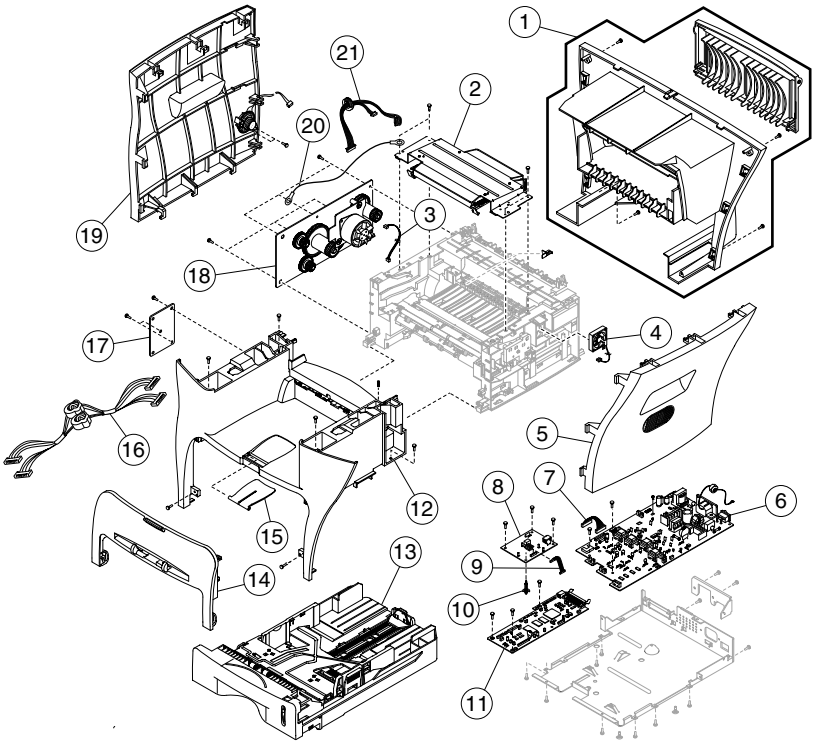

Assembly 2: Main assembly

Index	P/N	Units	Description
2-1	56P1914	1	Cover asm, rear
2	56P1902	1	Printhead, complete
3	56P1916	1	Cable, main drive motor
4	56P1915	1	Fan, cooling
5	56P1913	1	Cover, right
6	56P1904	1	Card asm, LVPS/HVPS - 110 V
6	56P1905	1	Card asm, LVPS/HVPS - 220 V
6	56P2028	1	Card asm, LVPS/HVPS - 240 V
7	56P1906	1	Cable, system to power supply
8	56P1918	1	Card asm, modem (Americas)
8	56P1986	1	Card asm, modem (West Europe)
8	56P1987	1	Card asm, modem (S. Africa)
8	56P1988	1	Card asm, modem (Asia)
8	56P1989	1	Card asm, modem (Australia)
9	56P1984	1	Cable, modem card to system
10	56P1919	1	Standoff, modem card
11	*56P2416	1	Card asm, system
12	56P1908	1	Cover asm, middle
13	56P1911	1	Tray asm, paper
14	56P1910	1	Cover asm, cartridge access
15	56P1909	1	Extender, output bin
16	*56P2418	1	Cable, scanner to system
17	*56P2417	1	Card asm, scanner
18	56P1901	1	Drive asm, main
19	56P1912	1	Cover, left, w/speaker
20	56P1985	1	Cable, main drive ground
21	56P1903	1	Cable, printhead

*** Note:** Whenever a part is replaced in a machine with serial number below S8374290, all three parts must be replaced at the same time.

Assembly 3: Frame assembly

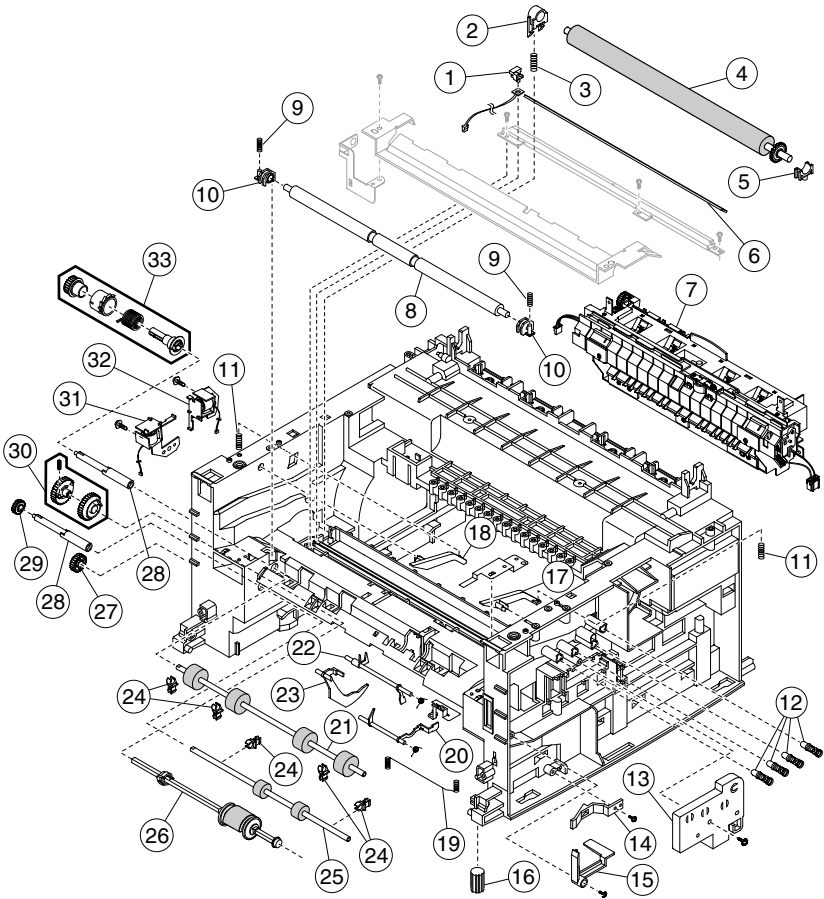

Assembly 3: Frame assembly

Index	P/N	Units	Description
3-1	56P1963	1	LED, pre-transfer
2	56P1965	1	Bearing, left transfer roller
3	56P1966	1	Spring, transfer roll bearing
4	56P1917	1	Roller asm, transfer
5	56P1967	1	Bearing, right transfer roller
6	56P1964	1	Lens, pre-transfer LED
7	56P1979	1	Fuser, complete, 110 V
7	56P1980	1	Fuser, complete, 220 V
7	56P1990	1	Fuser, complete, 240 V
8	56P1968	1	Roller, registration
9	56P1970	2	Spring, registration roller
10	56P1969	2	Bearing, registration roller
11	56P1953	2	Spring, cartridge latch
12	56P1948	4	Contact, high voltage
13	56P1949	1	Cover, HV contact
14	56P1950	1	Latch, paper tray
15	56P1951	1	Actuator, cover open
16	56P1947	2	Foot, rubber
17	56P1952	1	Latch, right cartridge
18	56P1954	1	Latch, left cartridge
19	56P1958	1	Contact, transfer roll
20	56P1957	1	Actuator, manual paper feed
21	56P1959	1	Roller, main paper feed
22	56P1955	1	Actuator, paper feed
23	56P1956	1	Actuator, paper empty
24	56P1960	5	Bearing, feed roller
25	56P1961	1	Roller, paper tray feed
26	56P1962	1	Roller asm, paper tray pick
27	56P1978	1	Gear, roller idler
28	56P1976	2	Coupling, shaft
29	56P1977	1	Gear, registration roller
30	56P1973	1	Gear asm, pick roll
31	56P1972	1	Solenoid, main paper feed
32	56P1971	1	Solenoid, paper tray pick roll

Assembly 3 (cont.): Frame assembly

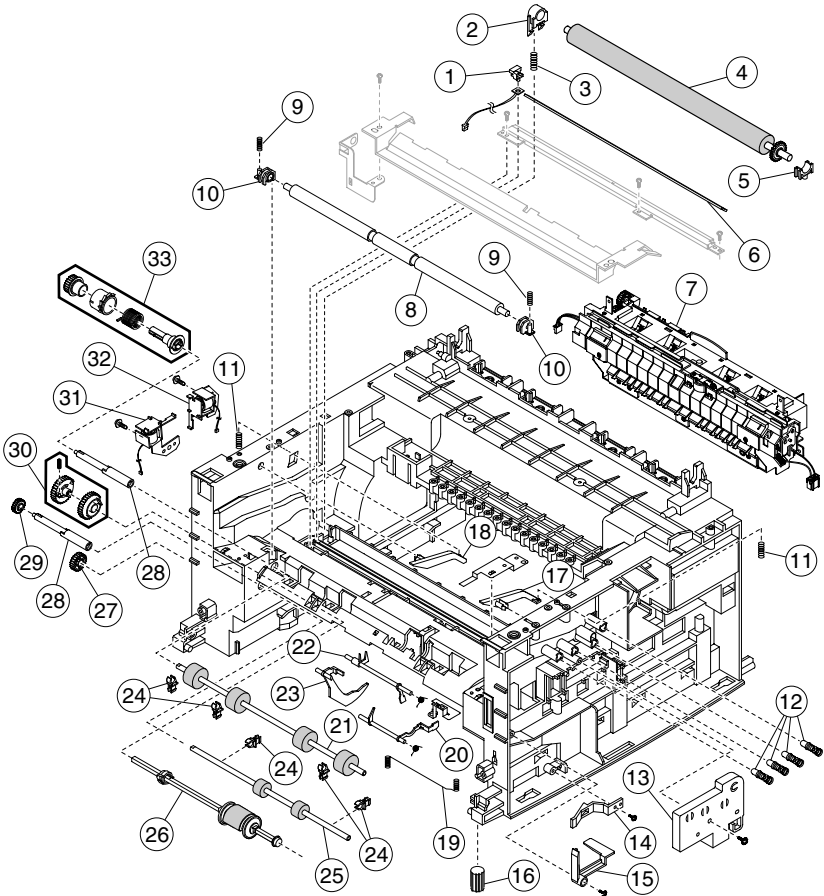

Assembly 3 (cont.): Frame assembly

Index	P/N	Units	Description
33	56P1975	1	Clutch asm, main paper feed
NS	1339526	1	Line cord, US, Canada, Mexico, Costa Rica, Guatemala, Panama, Puerto Rico, Honduras, Nicaragua, El Salvador, Dominican Republic
NS	1339527	1	Line cord, Australia, New Zealand
NS	1339528	1	Line cord, Hong Kong, Malaysia, Singapore, Ireland, UK
NS	1339529	1	Line cord, Austria, Belgium, Czech/Slav, Finland, France, Germany, Greece, Hungary, Iceland, Italy, Luxembourg, Netherlands/Holland, Norway, Poland, Portugal, Russia, Spain, Sweden, Turkey, Brazil (HV) Paraguay
NS	1339531	1	Line cord, Switzerland
NS	1339532	1	Line cord, Sri Lanka, South Africa
NS	1339533	1	Line cord, Chile, Uruguay
NS	1339534	1	Line cord, Denmark
NS	1339544	1	Line cord, Argentina
NS	1339548	1	Line cord, Brazil (LV)
NS	43H5545	1	Line cord, China
NS	7372151	1	Packaging, field relocation

4038-001

Index

A

- abbreviations 1-10
- abnormal image prints 2-29
 - back side contamination 2-29
 - black spots 2-29
 - horizontal shock lines 2-29
 - white or black spots/voids 2-29
- Adobe Illustrator
 - illustrations print incorrectly 2-15

C

- card stocks 1-2
- cleaning the machine 1-5
 - inside 1-6
 - outside 1-5
 - photoconductor drum 1-9
 - scan unit 1-8
- clear all memory 3-1
- configuration modes 3-1
 - clear all memory 3-1
 - dial mode 3-2
 - error rate 3-2
 - modem speed 3-3
 - park CCD module 3-4
 - print properties 3-5
 - send level 3-7
 - system settings report 3-7
- contrast
 - for copying 3-19
- customizing settings 3-18
 - advanced 3-21
 - content 3-18
 - darkness 3-19
 - number 3-19
 - scale 3-20

D

- dial mode 3-2
- DRAM memory test 3-8
- drum
 - clean 1-9

E

- envelopes 1-2
- error message 2-2
 - bypass jam 2-2
 - door open 2-3
 - fuser error 2-4
 - jam 2-3
 - load bypass 2-4
 - LSU error 2-4
 - memory full 2-4
 - no cartridge 2-4
 - no paper 2-4
 - open heat error 2-5
 - overheat 2-5
 - paper jam 2-6
 - paper jam 1 2-7
 - paper jam 2 2-8
 - power failure 2-8
 - time/date prompt 2-9
 - toner empty 2-9
 - toner low 2-9
- error rate 3-2

F

- faxing problems 2-19
 - #s in memory dial incorrectly 2-19
 - blank areas at bottom of page 2-20
 - buttons not working 2-19
 - docs not stored in memory 2-20
 - document does not feed 2-19
 - does not send 2-19
 - fax received with poor quality 2-19
 - incoming fax blank spaces 2-19
 - incoming fax stretched words 2-20
 - lines on documents sent 2-20
 - no dial tones 2-19
 - no display 2-19
 - not connected to another fax 2-20
 - not received automatically 2-19
 - not working 2-19

L

- labels 1-2
- Laser notices vii
 - class 1 label viii
- laser notices
 - advisory label vii
- locations 5-1
 - ADF paper path 5-14
 - cross-section of machine 5-3
 - engine paper path/paper jams 5-15
 - front view 5-1
 - HVPS/LVPS card 5-6
 - modem card 5-8
 - operator panel 5-4
 - operator panel card 5-9
 - rear view 5-2
 - scanner card 5-10
 - system board 5-12

M

- machine tests 3-8
 - DRAM memory 3-8
 - modem 3-9
 - modem protocol log 3-9
 - motor, fan, solenoid 3-10
 - operator panel button 3-11
 - operator panel test 3-12
 - print quality pages 3-14
 - printhead test 3-13
 - ROM memory 3-15
 - scanner CCD and motor 3-16
 - sensor 3-16
- maintenance approach 1-9
- modem protocol log test 3-9
- modem speed 3-3
- modem test 3-9
- motor, fan, solenoid test 3-10

O

- operator panel button test 3-11
- operator panel test 3-12

P

- paper feed problems 2-11
 - blank copies 2-16
 - copies too dark 2-16
 - copies too light 2-16
 - copy image skewed 2-16
 - envelopes skew 2-12
 - frequent jams 2-17
 - half of page is blank 2-14
 - illustrations print incorrectly 2-15
 - image rubs off easily 2-16
 - LCD does not turn on 2-15
 - low copies from cartridge 2-17
 - machine does not print 2-13
 - marks, spots on copies 2-16
 - multiple sheets do not feed 2-11
 - paper does not feed 2-12
 - paper keeps jamming 2-12
 - paper skews or buckles 2-11
 - paper sticks together 2-11
 - print job slow 2-14
 - repeated error with USB 2-15
 - smears, lines on copies 2-16
 - text garbled 2-14
 - text incomplete 2-14
 - text wrong 2-14
 - transparencies stick together 2-12
- park CCD module 3-4
- part number index X-5
- photoconductor drum
 - cleaning 1-9
- plain paper 1-2
- print materials 1-2
 - paper 1-3
 - selecting 1-2
 - speciality media 1-3
- print properties 3-5
 - extras 3-6
 - graphics 3-6
 - layout 3-6
 - paper 3-6

print quality checks 2-21

- back of printout dirty 2-24
- back side contamination 2-29
- background in print area 2-26
- background scatter 2-23
- black or dark image 2-25
- black spots 2-29
- black spots/voids 2-29
- black vertical band 2-21
- blank page prints 2-28
- blurry horizontal stripes 2-22
- character voids 2-25
- curl or wave 2-24
- dark horizontal stripes 2-22
- dark spots periodically 2-22
- faded areas 2-21
- gray background 2-26
- horizontal shock lines 2-29
- image occurs at intervals 2-26
- loose toner 2-25
- misformed characters 2-23
- page skew 2-23
- print density uneven 2-25
- printed image light 2-24
- thin black vertical line 2-21
- toner smear 2-22
- vertical white streak 2-21
- white spots periodically 2-22
- white spots/voids 2-29
- wrinkles and creases 2-24

print quality pages test 3-14

printhead test 3-13

R

removals 4-1

- ADF, pad 4-17
- ADF, pick roller 4-16
- card cage 4-24
- CCD module assembly 4-18
- covers, cartridge access 4-1
- covers, left side 4-11
- covers, middle 4-3
- covers, rear 4-5
- covers, right side 4-14
- covers, scanner assembly 4-7
- fan 4-30

- fuser 4-31
- HVPS contact 4-32
- LVPS/HVPS card 4-33
- main drive assembly 4-36
- main feed roller solenoid 4-41
- main paper feed roller 4-38
- manual paper feed sensor 4-44
- modem card 4-46
- operator panel 4-49
- paper empty sensor actuator 4-51
- paper feed sensor actuator 4-53
- paper tray feed roller 4-55
- paper tray pick roller asm 4-56
- paper tray solenoid 4-60
- printhead 4-62
- scanner assembly 4-63
- scanner assembly cushion 4-70
- scanner assembly hinge 4-71
- scanner card assembly 4-67
- system board 4-72
- transfer roll 4-75

ROM memory test 3-15

S

safety information xvii

scan unit

- cleaning 1-8

scanner CCD module/motor test 3-16

scanning problems 2-18

- does not work 2-18
- very slow 2-18

sensor test 3-16

service checks 2-30

- cooling fan 2-30
- dead machine 2-32
- document cover open switch 2-31
- main drive motor 2-31
- oper panel, scanner card asm 2-33

T

tools 1-9

transparency films 1-2

U

USB connection

- error occurs repeatedly 2-15

4038-001

Part number index

P/N	Description	Page
1339526	Line cord	7-9
1339527	Line cord	7-9
1339528	Line cord	7-9
1339529	Line cord	7-9
1339531	Line cord	7-9
1339532	Line cord	7-9
1339533	Line cord	7-9
1339534	Line cord	7-9
1339544	Line cord	7-9
1339548	Line cord	7-9
43H5545	Line cord	7-9
56P1901	Drive asm, main	7-5
56P1902	Printhead, complete	7-5
56P1903	Cable, printhead	7-5
56P1904	Card asm, LVPS/HVPS - 110 V	7-5
56P1905	Card asm, LVPS/HVPS - 220 V	7-5
56P1906	Cable, system to power supply	7-5
56P1908	Cover asm, middle	7-5
56P1909	Extender, output bin	7-5
56P1910	Cover asm, cartridge access	7-5
56P1911	Tray asm, paper	7-5
56P1912	Cover, left, w/speaker	7-5
56P1913	Cover, right	7-5
56P1914	Cover asm, rear	7-5
56P1915	Fan, cooling	7-5
56P1916	Cable, main drive motor	7-5
56P1917	Roller asm, transfer	7-7
56P1918	Card asm, modem (Americas)	7-5
56P1919	Standoff, modem card	7-5
56P1922	Roller, ADF idler	7-3
56P1923	Kit asm, ADF pick roll/pad	7-3
56P1931	Cover asm, ADF access	7-3
56P1932	Cushion, document cover	7-3

4038-001

56P1933	Hinge, document cover	7-3
56P1934	Panel asm, operator	7-3
56P1935	Overlay, menu/select/return	7-3
56P1936	Overlay, main	7-3
56P1940	Module asm, CCD	7-3
56P1941	Cable, CCD	7-3
56P1947	Foot, rubber	7-7
56P1948	Contact, high voltage	7-7
56P1949	Cover, HV contact	7-7
56P1950	Latch, paper tray	7-7
56P1951	Actuator, cover open	7-7
56P1952	Latch, right cartridge	7-7
56P1953	Spring, cartridge latch	7-7
56P1954	Latch, left cartridge	7-7
56P1955	Actuator, paper feed	7-7
56P1956	Actuator, paper empty	7-7
56P1957	Actuator, manual paper feed	7-7
56P1958	Contact, transfer roll	7-7
56P1959	Roller, main paper feed	7-7
56P1960	Bearing, feed roller	7-7
56P1961	Roller, paper tray feed	7-7
56P1962	Roller asm, paper tray pick	7-7
56P1963	LED, pre-transfer	7-7
56P1964	Lens, pre-transfer LED	7-7
56P1965	Bearing, left transfer roller	7-7
56P1966	Spring, transfer roll bearing	7-7
56P1967	Bearing, right transfer roller	7-7
56P1968	Roller, registration	7-7
56P1969	Bearing, registration roller	7-7
56P1970	Spring, registration roller	7-7
56P1971	Solenoid, paper tray pick roll	7-7
56P1972	Solenoid, main paper feed	7-7
56P1973	Gear asm, pick roll	7-7
56P1975	Clutch asm, main paper feed	7-9
56P1976	Coupling, shaft	7-7
56P1977	Gear, registration roller	7-7
56P1978	Gear, roller idler	7-7
56P1979	Fuser, complete, 110 V	7-7

56P1980	Fuser, complete, 220 V	7-7
56P1983	Scanner, complete	7-3
56P1984	Cable, modem card to system	7-5
56P1985	Cable, main drive ground	7-5
56P1986	Card asm, modem (West Europe)	7-5
56P1987	Card asm, modem (S. Africa)	7-5
56P1988	Card asm, modem (Asia)	7-5
56P1989	Card asm, modem (Australia)	7-5
56P1990	Fuser, complete, 240 V	7-7
56P2028	Card asm, LVPS/HVPS - 240 V	7-5
56P2416	Card asm, system	7-5
56P2417	Card asm, scanner	7-5
56P2418	Cable, scanner to system	7-5
7372151	Packaging, field relocation	7-9

4038-001